

# PantoRouter<sup>®</sup>

## Assembly Guide

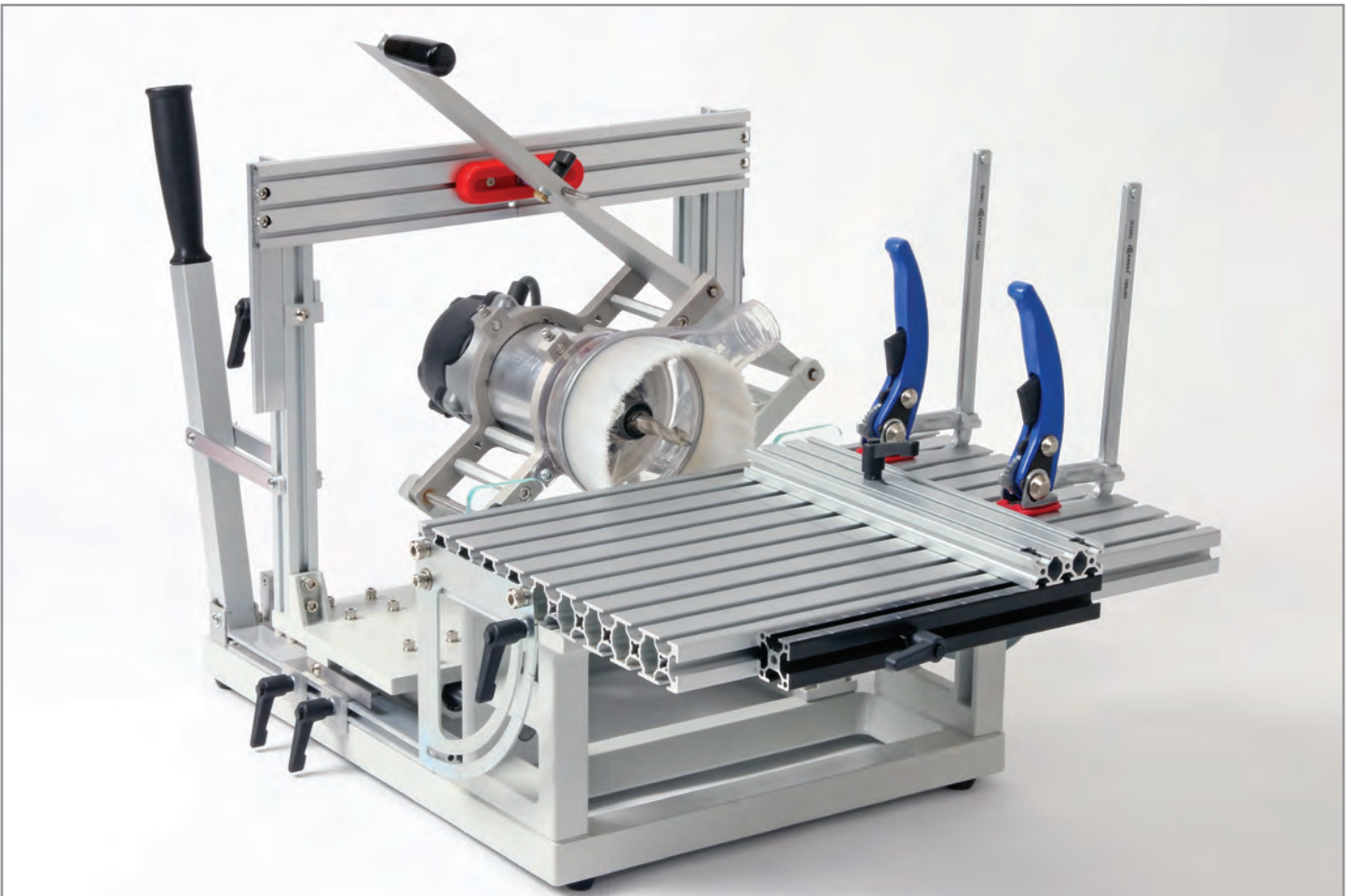

[www.PantoRouter.com](http://www.PantoRouter.com)  
[info@PantoRouter.com](mailto:info@PantoRouter.com)  
+1-877-333-7150

Copyright 2019 WoodCraft Solutions LLC

# General Assembly Diagram

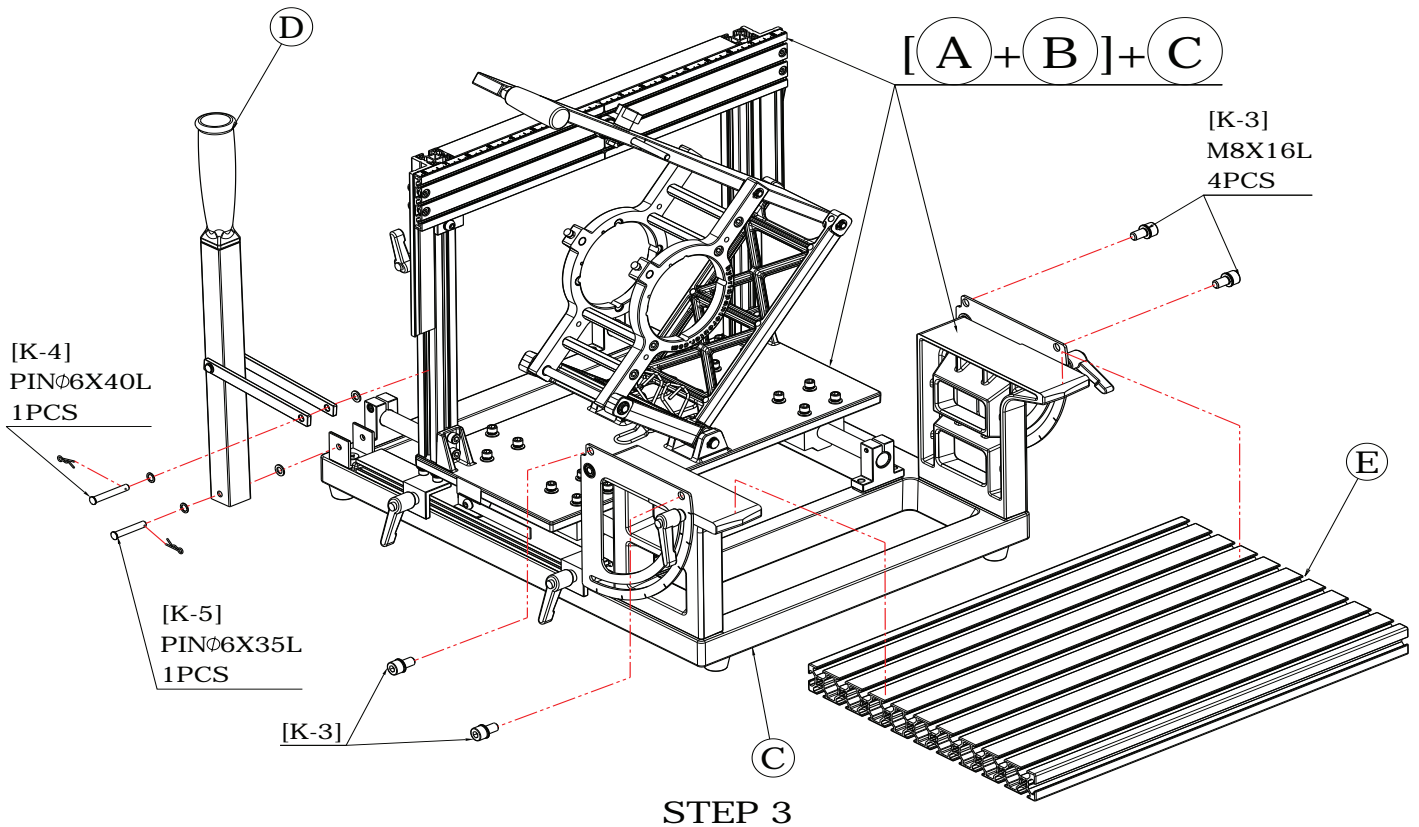
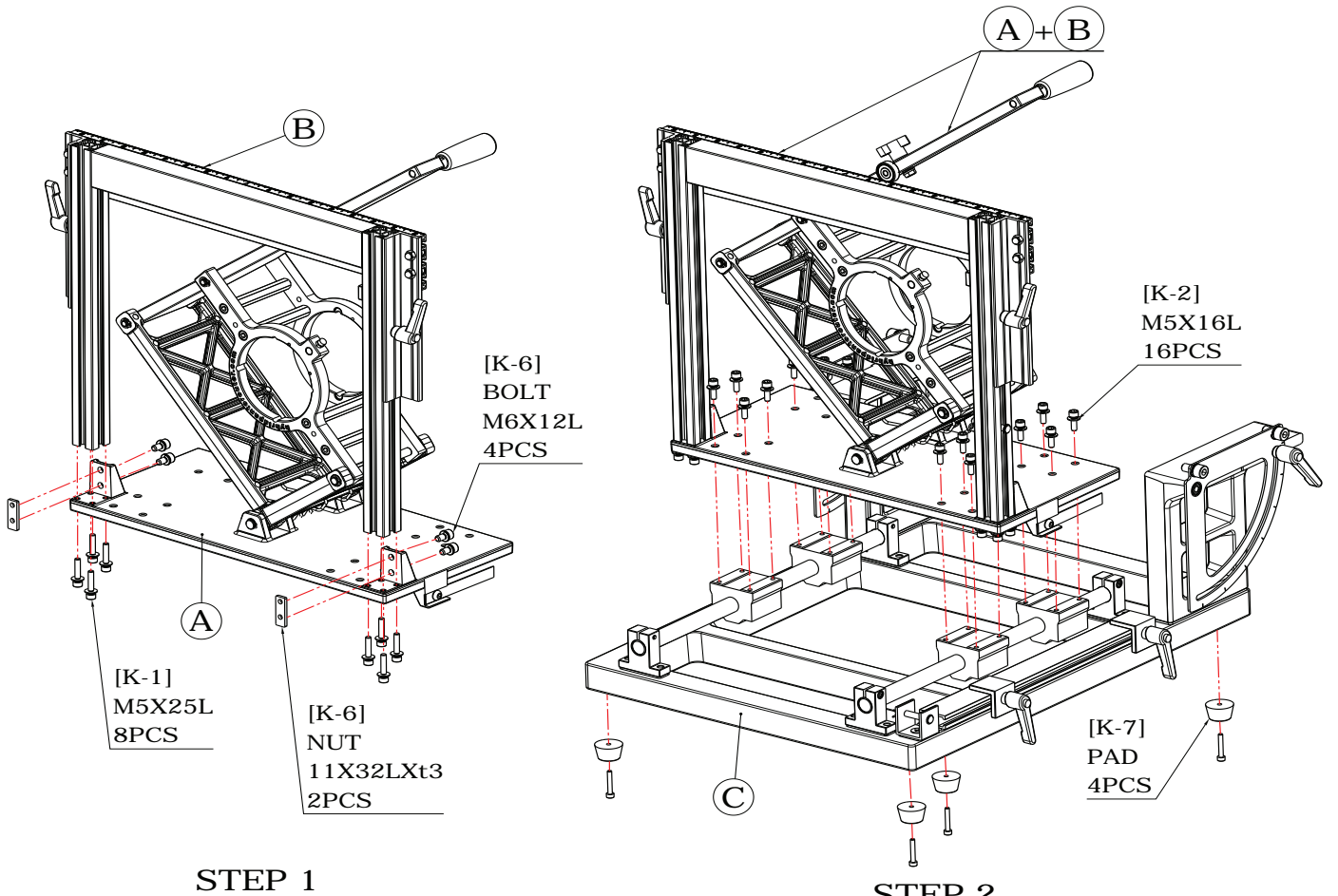

# Basic Components of the PantoRouter™

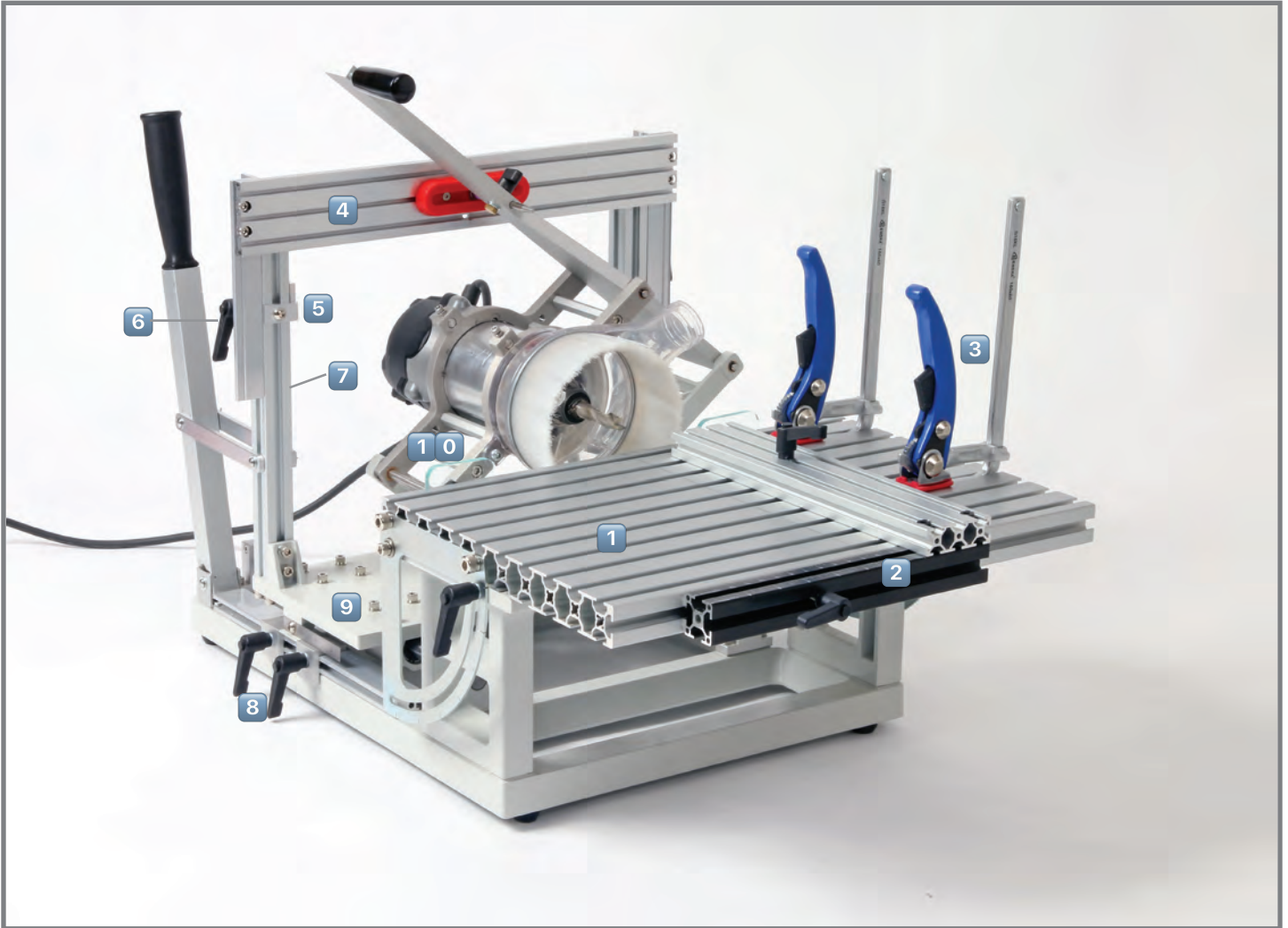

1. Table
2. Centering Scale Fence
3. T-Slot Lever Clamps
4. Template Holder
5. Thickness Gage
6. Template Holder Locking Lever
7. Template Holder Support Frame
8. Depth Stops
9. Pantograph Carriage
10. Pantograph

# PantoRouter™ Assembly Guide

©WoodCraft Solutions LLC, January 2019



We thank you for your PantoRouter™ purchase and we hope you find great pleasure in creating all kinds of traditional and innovative joinery. There's no better jig for mortise and tenons, box joints and machine-cut dovetails, but this is just the beginning of the tasks you can master with the PantoRouter™.

Your PantoRouter™ experience starts with a few minutes of assembly then grab our How-To Guide for basic instruction and some ideas to help you get started.

First, open the KITS box where you'll find all of the fasteners and hex wrenches. Together with this guide, you should be up and PantoRouting in short order.

Inspect the pieces for any possible shipping damage then lay them out and refer to the diagram to get a good idea of how they'll all fit together.

Kits K-1 and K-6 contain the cap screws for mounting the template holder frame to the pantograph carriage, and K-2 contains the screws to secure the carriage to the glideshaft bearings.

Open K-1, K-2, K-6 and K-8; the hex wrenches you'll need for assembly.

We recommend using the supplied hex wrenches or similar hand-held wrenches. Using a drill or impact driver for assembly can over-drive screws or strip threads.



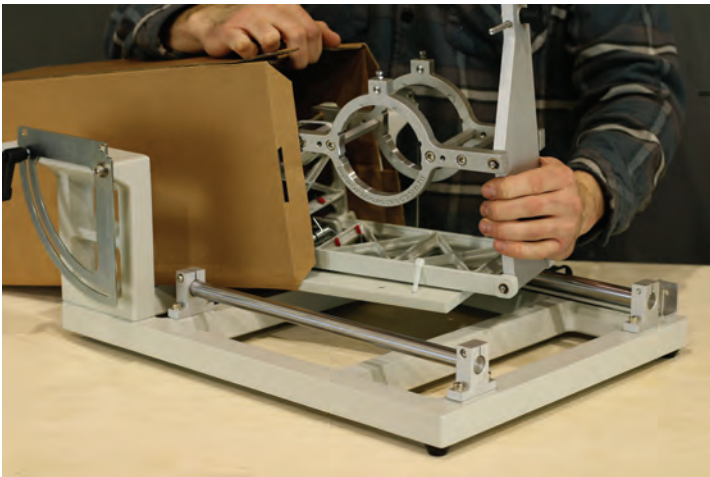

Remove the pantograph carriage from Box-A but don't cut the nylon tie straps yet.



Check the machined surfaces to make sure they're clean and smooth. If needed, remove paint but don't use sand cloth. A sharp blade will clean the surface in a few seconds.



Loosely thread the K-6 cap screws into the nut plates on both sides.



Slide the template holder frame (B) into place with the nut plates in the slots on both sides then snug but don't tighten the cap screws.

Hand-thread the eight K-1 cap screws through the pantograph carriage (A) and into the template holder support frame (B).

Tighten the cap screws using the hex wrench provided.

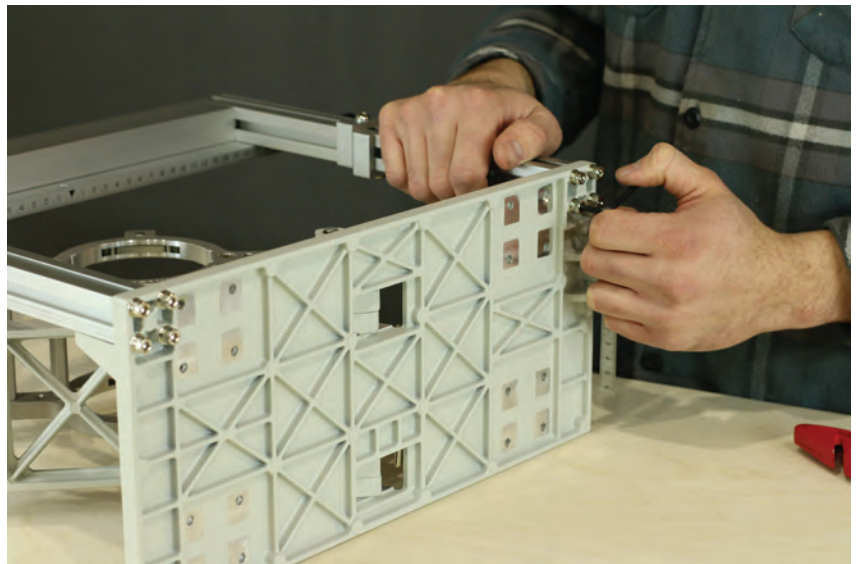



Using the hex wrench provided in Kit-8 tighten the cap screws to the plate nuts to secure the template holder frame. Clip the wire ties to access these cap screws.



Install the rubber feet to the bottom of the base frame without over-compressing the rubber.



Clean the machined landing pads from the underside of the pantograph carriage.

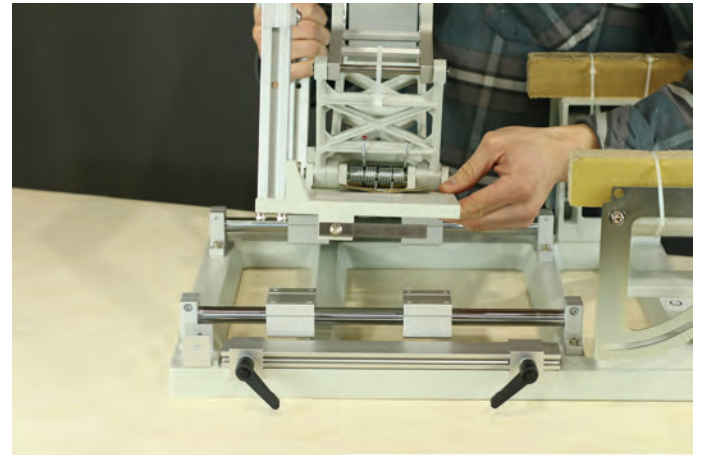

Position the pantograph carriage on the glideshaft bearings and align the screw holes. You might need to relocate the depth stop angles for the depth stop post to clear.

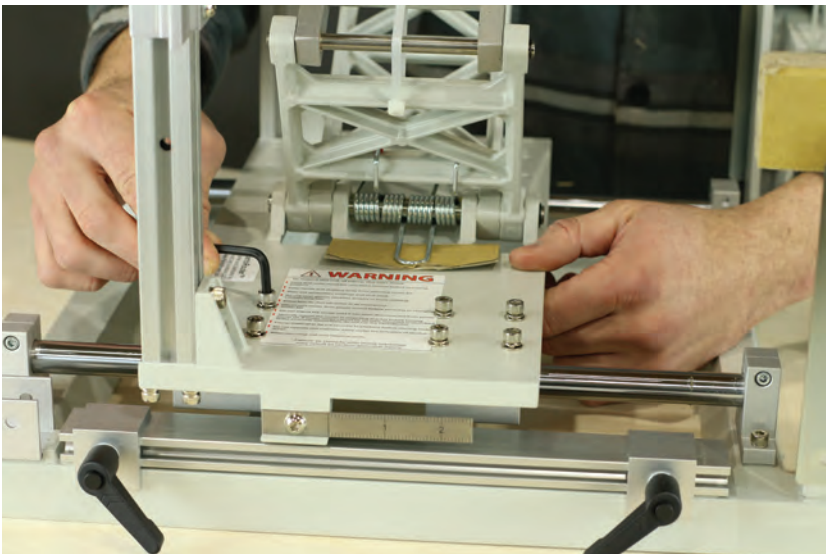

Tighten all 16 screws to secure the pantograph carriage to the glideshaft bearings.

The carriage should now move freely on the glide shafts.



Insert pin K-5 through the plunge lever bracket as shown with a washer on both sides. Secure with locking clip. Note the K-5 pin is shorter than K-4.

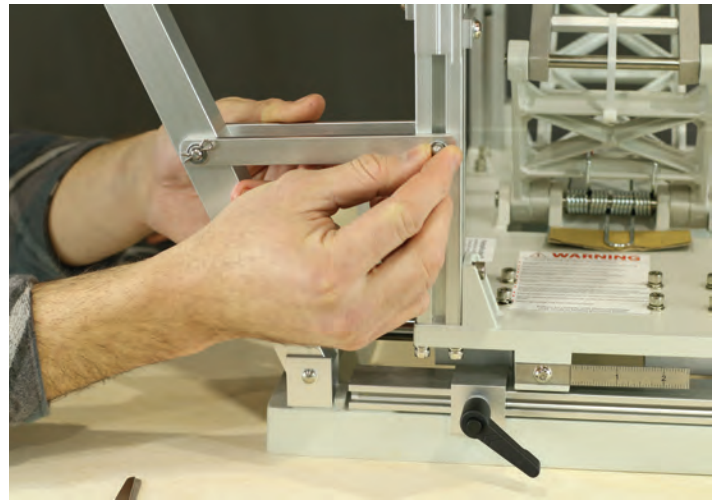

Insert K-4 through the plunge lever arms and template holder support post using a washer on both sides and lock with the clip. The lever should now control the movement of the pantograph carriage.



Loosen and move the depth stops if necessary to feel the full range of motion.

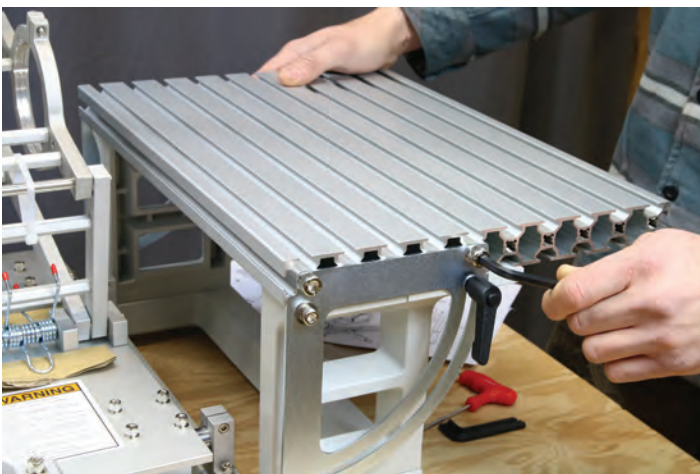

Hand-tighten all four table mounting cap screws (K-3) then secure the table to the protractor.

You can now loosen both protractor lock knobs and test the tilting table.



The Porter Cable 8902 router supplied with our Pro-Pack has a rack gear not used by the Pan-toRouter. Remove the two small screws and the gear. Do not remove the two pins pressed into the side of the router. The router mounts have notches to allow the router to pass through with the pins in place.

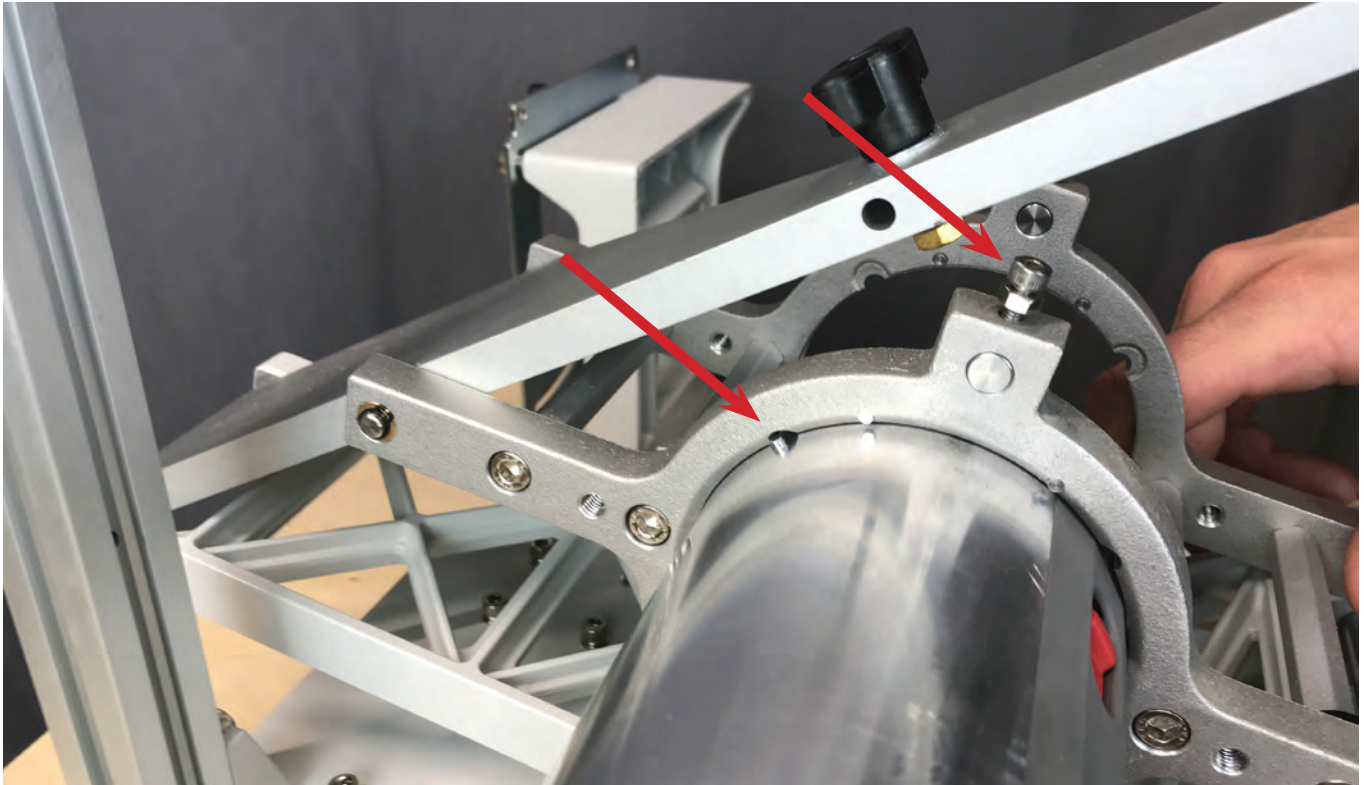

Loosen the two router mount cap screws but don't remove them. Align the pin with one of the slots in the rear router mount and slide the router through both router mounts.

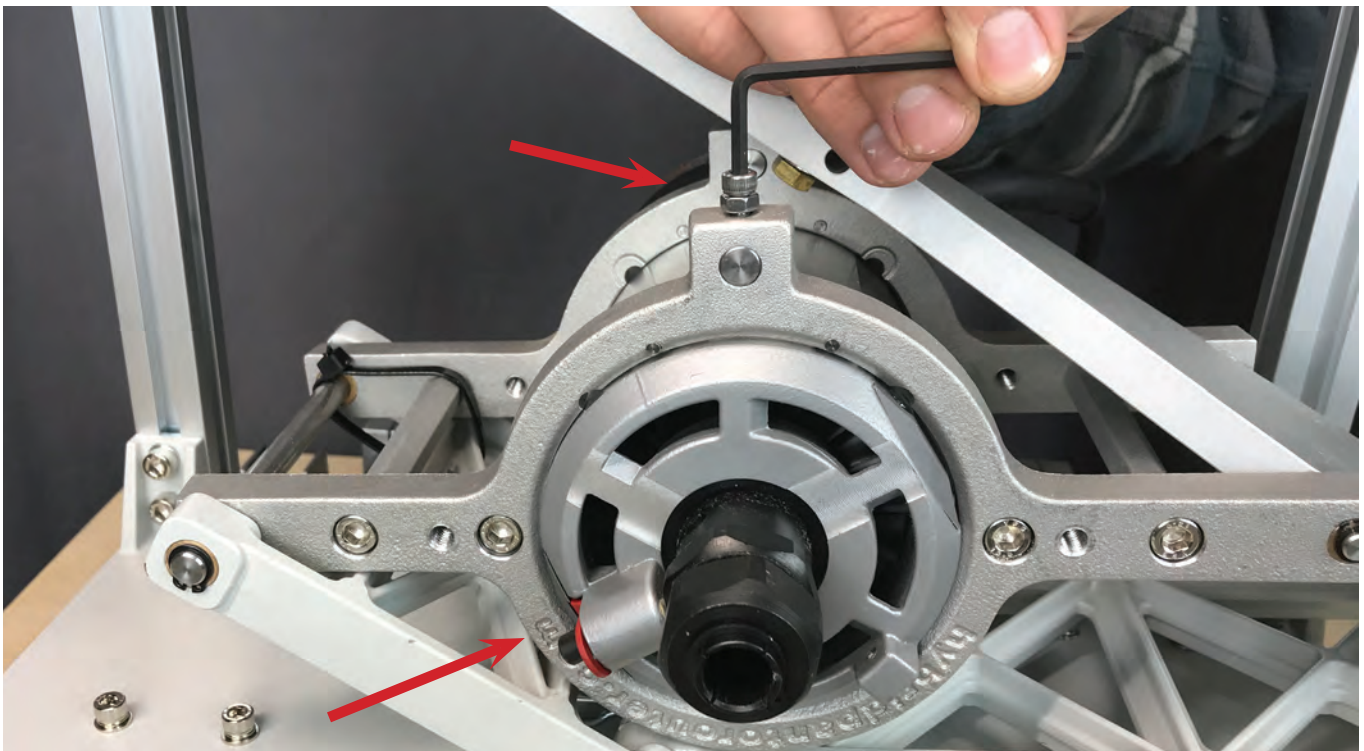

Push the router forward until the full dimension of the router body is just flush with the front face of the router mount.

Rotate the router so the rotor lock button is aligned with the "m" in [www.hybridpantorouter.com](http://www.hybridpantorouter.com) cast into the router mount. Tighten both router mount cap screws and locking nuts.



The dust collector hood attaches using two different screws. The countersunk screw goes on the discharge port side of the router mount. Use a small shaft screwdriver through the access hole to tighten it.



The round head machine screw (hex) secures the other end as shown. If the router is mounted correctly the operator can access the router rotor lock button through the opening for single-wrench bit changes.



We recommend using a hose that fits over the discharge port, not inside it. It helps to soften the hose cuff by holding it under hot tap water. It should slip right onto the dust collection hood and as it cools it will grip tenaciously.

You can now remove remaining nylon tie strap and cardboard cushions from the pantograph assembly.

Now that the basic assembly of the PantoRouter is complete continue on for directions to:

1. Calibrate the Template Holder
2. Setup and use the thickness gage
3. Scribe the centerline on the table
4. Assemble the centering-scale fence.

The How-To Guide has instructions and tips for mortise and tenon, box joints and variably-spaced dovetails. It also contains a chart showing bit and guide bearing combinations for different sized joints.

Most of the innovations added to the PantoRouter over the years have been in response to suggestions from our customers. We welcome your feedback and questions via email, phone or our website forum.

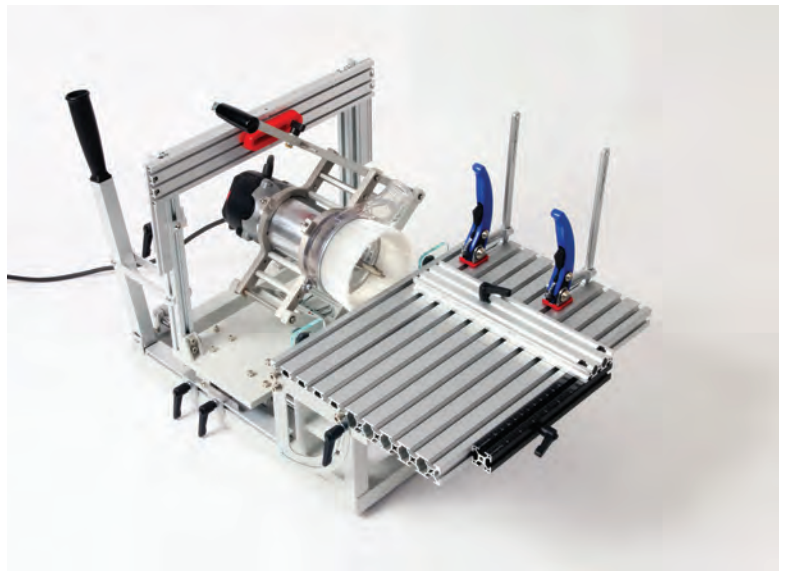

**Happy PantoRouting!**

# Calibrate the Template Holder

The template holder frame assembly is aligned at the factory but can shift slightly in transit so the following procedure might be necessary to bring it back into perfect alignment. Check alignment using a square before loosening the screws to see if adjustment is needed.

Many people can feel variation of about a thousandth of an inch (0.025mm), so aligning by touch is often highly accurate as well.

If adjustment is needed, loosen the screws holding the template holder frame cross rail to the frame posts. There are two holes on each side to access these screws.

Flush the top of the post and the cross rail and be sure the assembly is square. Re-tighten the screws on both sides.

Alignment of the template to the pantograph and table is critical for accurate joinery. The template holder must be perfectly square to the frame and must slide freely on the posts. Adjusting it is quick and easy using the following method.

Inspect the template holder checking for any sharp edges. Relieve edges with very fine sand cloth or a diamond file if necessary and wax the surfaces to lubricate.

Mount the template holder with the four screws on the sliders loosened. Tighten the lever knobs when the sliders are flush with the top of the posts.

Tighten the four screws once the template holder is aligned with the tops of both posts.

The template holder should now slide up and down freely and it should stay aligned to the template holder support frame.

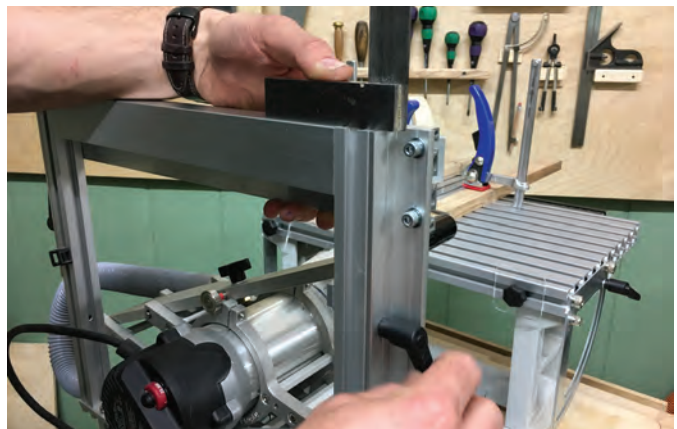
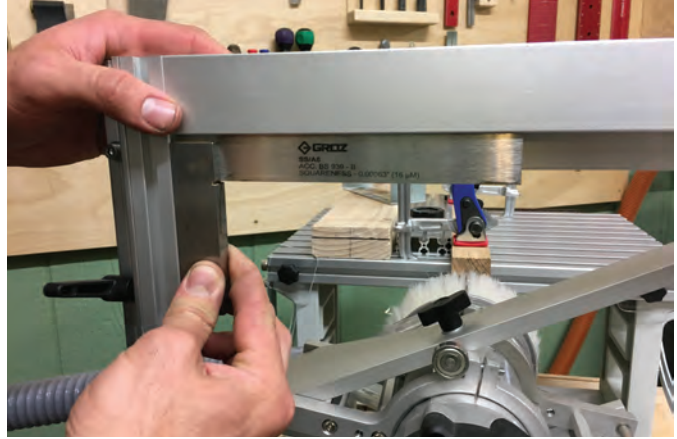

The template must be coplanar to the table (and the workpiece) in order to produce high quality joinery. This can be quickly checked after the template holder and template holder support frame have been squared and trued.

Cut a setup block from a piece of fine grain wood so it's square on the end then stand it up on the operator's side of the table. A piece about 1.5" X 1.5" X 3" works well.

Mount your centering jig (pointer) in the router and lock a guide bearing so it rides the top of the template holder. Rest the template holder on top of the thickness gage and lock both template holder slider locks. If the thickness gage is not set yet, lock the template holder with the centering jig about an inch above the table.



Scribe a small line (1/2" or so) in the setup block as shown. We highlighted the line with pencil for clarity. It's easiest to see the line when you're scribing across the side grain.

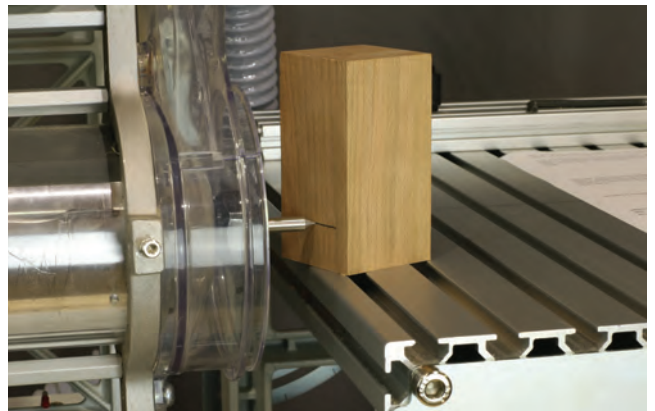

Move the guide bearing to the far side of the template holder, which moves the centering jig across the table. Scribe a second line next to the first.

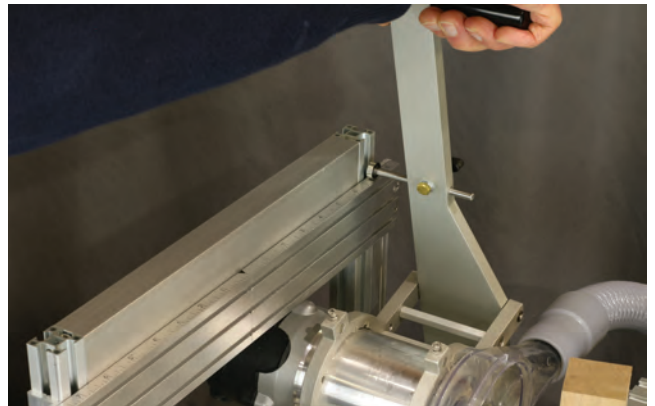

The two scribe marks should be identical or very nearly so. If they are off by more than the width of the scribe line, please call or email the distributor for assistance in dialing it in precisely. It only takes a few minutes and once adjusted precisely, your joinery will be perfect every time.

Contact information for your distributor is on the back cover of this guide.



# Setting the Thickness Gage

Centering joinery in your workpiece vertically is easily done on the PantoRouter using the built-in thickness gage. Once adjusted it is fast, accurate and repeatable.

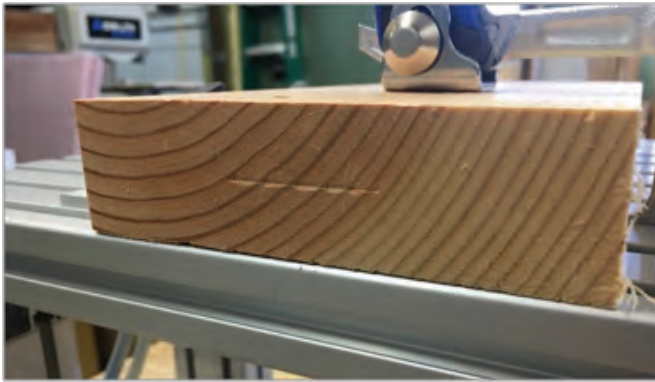

Start by marking the center of a workpiece.

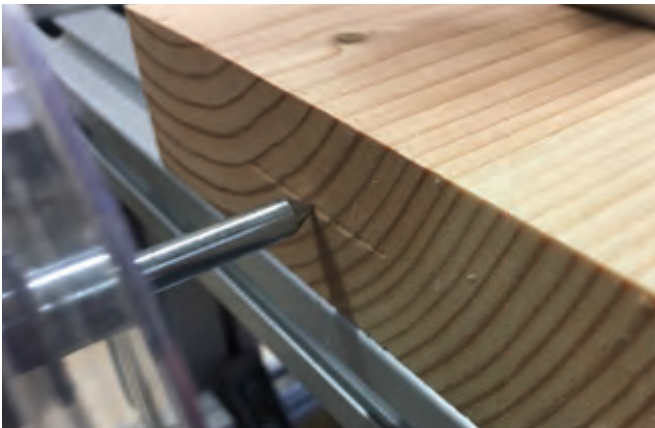

Install a centering jig (pointer) in the router in place of a bit. Loosen the template holder locking levers and move the router mount so the centering jig is at the centerline of the workpiece. Lock the template holder on both sides.



Locate one of the mortise and tenon templates at the zero mark side-to-side and in the center slot of the template holder. The templates are easily centered using a 6mm shaft through the template into the template holder centering hole. Lock the shaft.



With the template holder locked in place and the guide bearing shaft holding the pantograph on center, hold the workpiece under the template holder horizontal rail and slide the thickness gage up so it contacts the bottom of the workpiece. Tighten the locking screw securely.



Slide the second angle down to contact the thickness gage angle and lock it in place. This one serves as a placeholder in case you need to move the thickness gage. You can drop (lower) the thickness gage angle down and out of the way of the template holder then bring it back into position without having to go through the whole setup process again. You can also use this second angle when adjusting the thickness gage for precision.

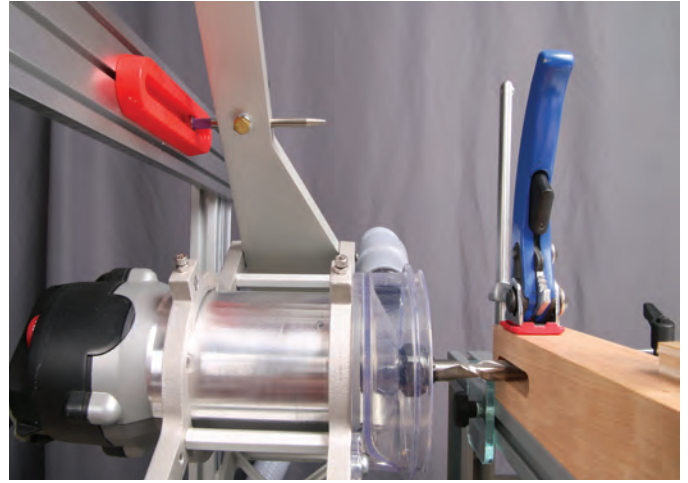

Mortises and tenons can be located in the center of the workpiece regardless of the thickness of the board. Rest the workpiece on the thickness gauge and lower the template holder rail to contact the top surface. Lock the template holder in place and the bit should cut the mortise or tenon in the center of your workpiece.

If the mortise or tenon is slightly off center you can micro-adjust the thickness gage by moving it up or down as needed. Measure both shoulders of a mortise and adjust the thickness gage until the two shoulders are dead on.



Tip:  
See the How-To Guide for setting up and clamping for mortises.

Start with a piece of hardwood over 1" thick. Mill it parallel on all four sides.

Mark the top of your workpiece, then make your first mortise with a 1/4" bit.

Measure the shoulders then move the gage up or down as needed by the difference between the two measurements.

Make your second mortise cut with a 3/8"

bit so it's in the same slot as the first cut.

Measure, adjust, then make your third cut if needed using a 1/2" bit. With this method you won't have wasted good wood.

Locate your end clamp for this test so it's not directly over your mortise cut. As the shoulder gets thinner, the clamp can deflect the wood. It's a good idea to make your test mortises about 3/4" deep.

# Finding and Marking the Table Centerline

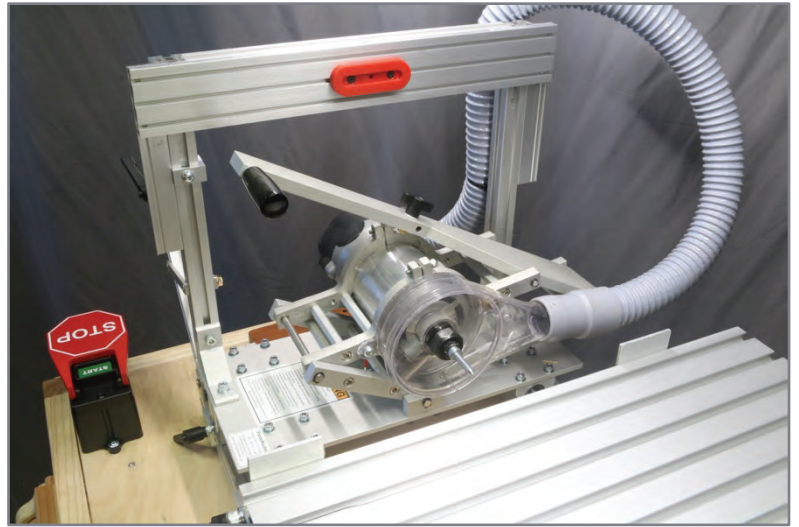
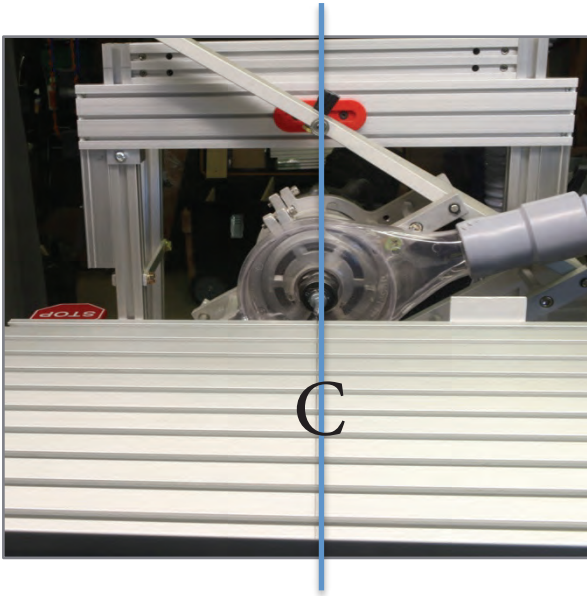

The PantoRouter™ transfers the shape of the template mounted on the template holder to the workpiece located on the table. Aligning the template, router bit and workpiece are essential to accurate joinery, and this is made fast and easy using the Centering Scale Fence.

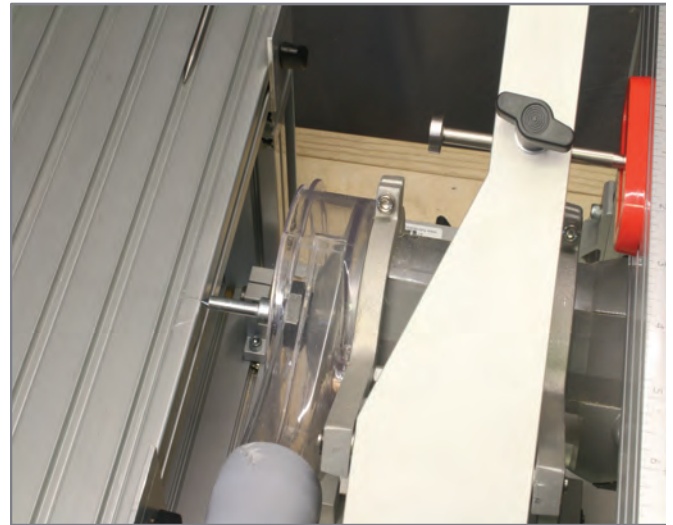

Insert the 6mm guide bearing shaft through the center hole of the template and into the centering hole in the template holder then mount the centering jig (pointer) in the router collet. Plunge the pantograph carriage forward and lower the template holder so the tip of the centering jig rests gently on the top edge of the table.

Lock the pantograph carriage using the two depth stops on the operator's side.



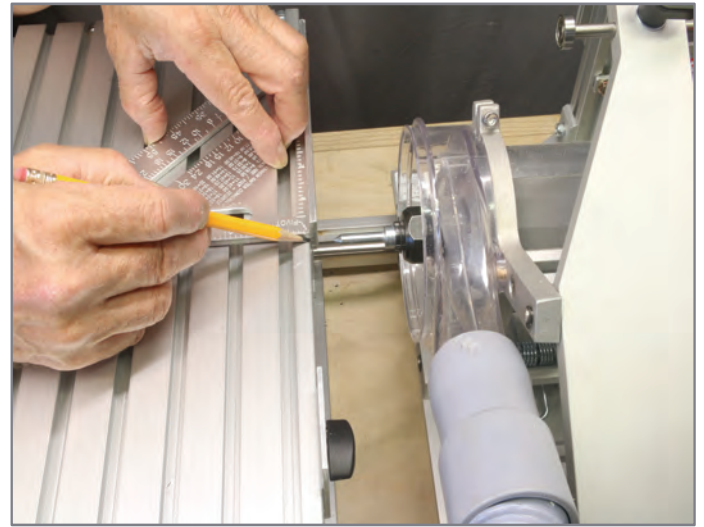
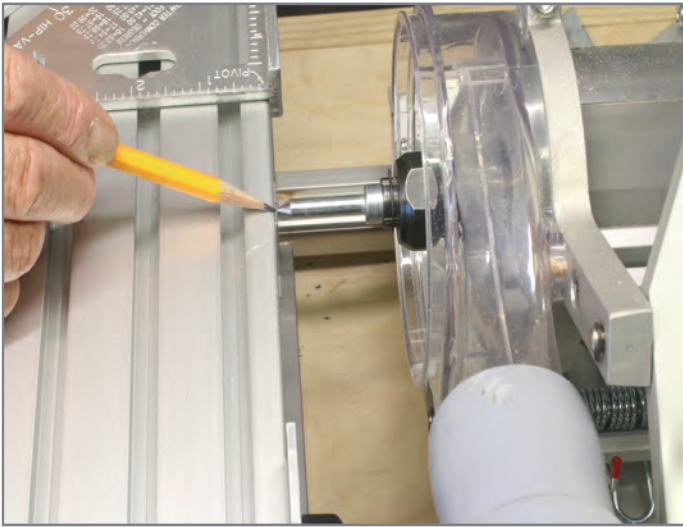

This is dead center of the table relative to the center of the template and router, so carefully mark this position and use a square to draw a line from this point across the center of the table. This mark can be in pencil, ink or scribed into the aluminum.

To center your workpiece on the table you can mark the center of your workpiece then locate it on the marked or scribed centerline.

You can also use the centering-scale fence accessory to reference the centerline, which auto-centers the workpiece.

See the Centering Scale Fence setup procedure later in this guide.



Measure the width of the workpiece then set that value on the centerline to automatically center your workpiece.



Always lock the rear lever first then the lever knob on the top of the fence.

# Setting up the Centering Scale Fence

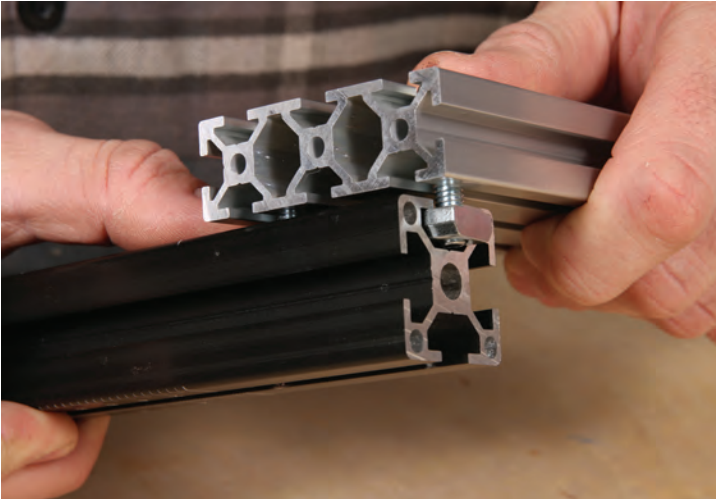

Slide the T-nuts into the top slot of the centering-scale rail so the scale of your choice (inch-scale or metric) is facing up. Barely snug the cap screws but don't tighten yet.



Slide the black slider nuts into the slot in the back edge and the foot nut into the top of the table keeping the whole assembly loose.



Align the fence with a square and lock the fence lever knob.  
Use both clamps to hold the fence perfectly perpendicular to the back edge of the table.





Align the laser-etched “Zero” mark with the edge of the fence rail then lock the rear lever knob.

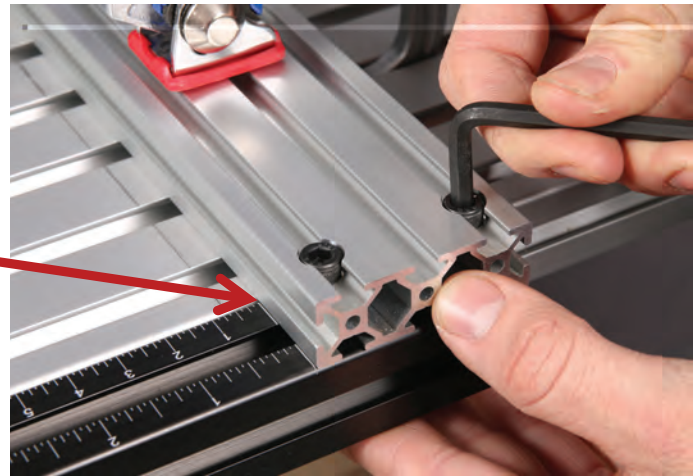

Secure the fence rail to the half-scale rail by tightening the cap screws.



You can use the Centering-Scale Fence to center your workpiece. Measure the width of your piece on the outer scale then set the measured value at the centerline of your table.

In this case the workpiece is 4-1/2” wide.

Since the inner scale is only half the actual measurement, the workpiece will be centered when positioned against the fence.

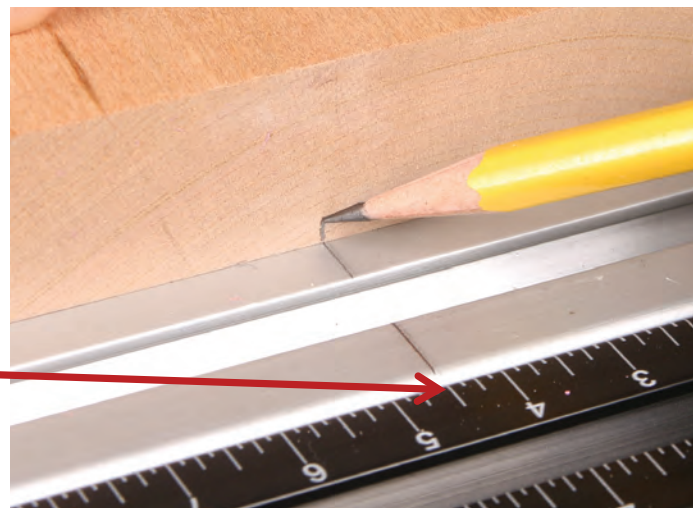

# MORTISE AND TENON GUIDE BEARING AND BIT SELECTION

Tenon Size	GB	Bit	
		GB	Bit
1/8"	6	1/2	1/2
	10	1/2	1/2
1/4"	22	3/4	3/4
	35	1	1
3/8"	10	3/8	3/8
	15	1/2	1/2
1/2"	10	1/4	1/4
	15	3/8	3/8
	22	1/2	1/2
	35	3/4	3/4
	48	1	1
3/4"	22	1/4	1/4
	35	1/2	1/2
	48	3/4	3/4
1"	35	1/4	1/4
	48	1/2	1/2



It's best to use larger guide bearings and bits where possible.  
The 1/2" spiral upcut bit works with every size.

The 35mm (yellow) and 48mm (orange) guide bearings come with the Monster Set along with 3/4" and 1" straight cut bits.

## FORMULA TO CREATE CUSTOM TEMPLATES:

$$2(\text{TENON THICKNESS} + \text{BIT DIAM}) - \text{GUIDE BEARING}$$

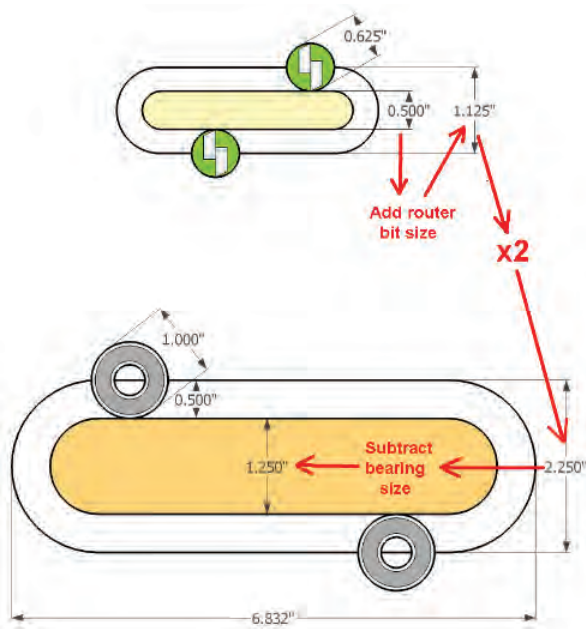

Bit mm	Guide Bearing mm	Tenon Thickness mm
12	19	12
12	15	10
12	10	8
12	6	6

MM	Decimal Inch	Fraction Inch
3.175	0.125	1/8
6	0.236	
6.35	0.250	1/4
10	0.394	
12	0.472	
12.7	0.500	1/2
15	0.591	
19	0.748	3/4
22	0.866	
25.4	1.000	1
35	1.378	
48	1.890	

## Decimal Equivalents

English	Metric	Decimal	English	Metric	Decimal	English	Metric	Decimal	English	Metric	Decimal
..	.1	.0039	45	..	.0820	5	..	.2055	<b>7/16</b>	..	<b>.4375</b>
	.2	.0079	44	..	.0860	4	..	.2090	29/64	..	.4531
..	.3	.0118	43	..	.0890	3	..	.2130	<b>15/32</b>	..	<b>.4687</b>
80	..	.0135	42	..	.0935	<b>7/32</b>	.	<b>.2187</b>	..	12.	.4724
79	.	.0145	<b>3/32</b>	..	<b>.0937</b>	2	..	.2210	31/64	..	.4844
<b>1/64</b>	..	<b>.0156</b>	41	..	.0960	1	..	.2280	<b>1/2</b>	..	<b>.5000</b>
..	.4	.0157	40	..	.0980	A	..	.2340	..	13.	.5118
78	.	.0160	39	..	.0995	<b>15/64</b>	..	<b>.2344</b>	33/64	..	.5156
77	.	.0180	38	..	.1015	..	6.	.2362	17/32	..	.5312
.	.5	.0197	37	..	.1040	B	..	.2380	35/64	.	.5469
76	.	.0200	36	..	.1065	C	..	.2420	..	14.	.5512
75	.	.0210	<b>7/64</b>	..	<b>.1094</b>	D	..	.2460	<b>9/16</b>	..	<b>.5625</b>
74		.0225	35	..	.1100	<b>1/4</b>	..	<b>.2500</b>	37/64	..	.5781
.	.6	.0236	34	..	.1110	F	..	.2570	..	15.	.5906
73	..	.0240	33	..	.1130	G	..	.2610	19/32	..	.5937
72	..	.0250	32	..	.1160	<b>17/64</b>	..	<b>.2656</b>	39/64	..	.6094
71	..	.0260	..	3.	.1181	H	..	.2660	<b>5/8</b>	..	<b>.6250</b>
..	.7	.0276	31	..	.1200	I	..	.2720	..	16.	.6299
70	..	.0280	<b>1/8</b>	..	<b>.1250</b>	..	7.	.2756	41/64	..	.6406
69	..	.0292	30	..	.1285	J	..	.2770	21/32	..	.6562
68	..	.0310	29	..	.1360	K	..	.2810	..	17.	.6693
<b>1/32</b>	..	<b>.0312</b>	28	..	.1405	<b>9/32</b>	..	<b>.2812</b>	43/64	..	.6719
..	.8	.0315	<b>9/64</b>	..	<b>.1406</b>	L	..	.2900	<b>11/16</b>	..	<b>.6875</b>
67	..	.0320	27	..	.1440	M	..	.2950	45/64	..	.7031
66	..	.0330	26	.	.1470	<b>19/64</b>	..	<b>.2969</b>	..	18.	.7087
65	..	.0350	25	..	.1495	N	..	.3020	23/32	..	.7187
.	.9	.0354	24	..	.1520	<b>5/16</b>	..	<b>.3125</b>	47/64	..	.7344
64	..	.0360	23	..	.1540	..	8.	.3150	..	19.	.7480
63	..	.0370	<b>5/32</b>	.	<b>.1562</b>	O	..	.3160	<b>3/4</b>	..	<b>.7500</b>
62	..	.0380	22	..	.1570	P	..	.3230	49/64	..	.7656
61	..	.0390	..	4.	.1575	<b>21/64</b>	..	<b>.3281</b>	25/32	..	.7812
..	1.	.0394	21	..	.1590	Q	..	.3320	..	20.	.7874
60	..	.0400	20	..	.1610	R	..	.3390	51/64	..	.7969
59	..	.0410	19	..	.1660	<b>11/32</b>	..	<b>.3437</b>	<b>13/16</b>	..	<b>.8125</b>
58	..	.0420	18	.	.1695	S	..	.3480	..	21.	.8268
57	.	.0430	<b>11/64</b>	..	<b>.1719</b>	..	9.	.3543	53/64	..	.8281
56	..	.0465	17	..	.1730	T	..	.3580	27/32	..	.8437
<b>3/64</b>	..	<b>.0469</b>	16	..	.1770	<b>23/64</b>	..	<b>.3594</b>	55/64	..	.8594
55	..	.0520	15	..	.1800	U	..	.3680	..	22.	.8661
54	..	.0550	14	..	.1820	<b>3/8</b>	..	<b>.3750</b>	<b>7/8</b>	..	<b>.8750</b>
53	..	.0595	13	..	.1850	V	..	.3770	57/64	..	.8906
<b>1/16</b>	.	<b>.0625</b>	<b>3/16</b>	..	<b>.1875</b>	W	..	.3860	..	23.	.9055
52	..	.0635	12	..	.1890	<b>25/64</b>	..	<b>.3906</b>	29/32	..	.9062
51	..	.0670	11	..	.1910	..	10.	.3937	59/64	..	.9219
50	..	.0700	10	..	.1935	X	..	.3970	<b>15/16</b>	..	<b>.9375</b>
49	.	.0730	9	..	.1960	Y	.	.4040	..	2	.9449
48	..	.0760	..	5.	.1968	<b>13/32</b>	..	<b>.4062</b>	61/64	..	.9531
<b>5/64</b>	..	<b>.0781</b>	8	..	.1990	Z	..	.4130	31/32	..	.9687
47	..	.0785	7	..	.2010	27/64	..	.4219	..	2	.9842
..	2.	.0787	<b>13/64</b>	..	<b>.2031</b>	..	11.	.4331	63/64	..	.9844
46	..	.0810	6	..	.2040				<b>1</b>	25.4	<b>1.000</b>



Copyright 2018 - WoodCraft Solutions LLC

Distributed in North and South America,  
New Zealand and Australia by:  
WoodCraft Solutions LLC

[www.PantoRouter.com](http://www.PantoRouter.com)  
[info@PantoRouter.com](mailto:info@PantoRouter.com)  
+1-877-333-7150

## Box joints in minutes, with no fitting

Even easier than it cranks out dovetails, the PantoRouter uses a single steel template to make immaculate box joints in two sizes, with perfect joints right off the machine—no sample boards or fitting required. For 1/2-in. fingers, use the 1/2-in. bit supplied, and skip every other slot in the template. For 1/4-in. box joints on smaller projects, use the smaller bit and every slot on the template. The 10mm guide bearing is always the same.

There isn't much more to say, other than the fact that the template fingers are fixed, meaning only certain board widths will give perfect fingers on the ends of a joint. If you don't mind partial fingers, you can use workpieces of any width. Also, the tall box joint template lets you cut joints in stock up to a hefty 1-1/4 in. thick.

Soon you will be finding all sorts of reasons to use these clean-looking joints, from shop trays and cabinet drawers to quick gifts for friends and family. Flip through the photos for all of the tips and steps.

### Cut one side of the joint

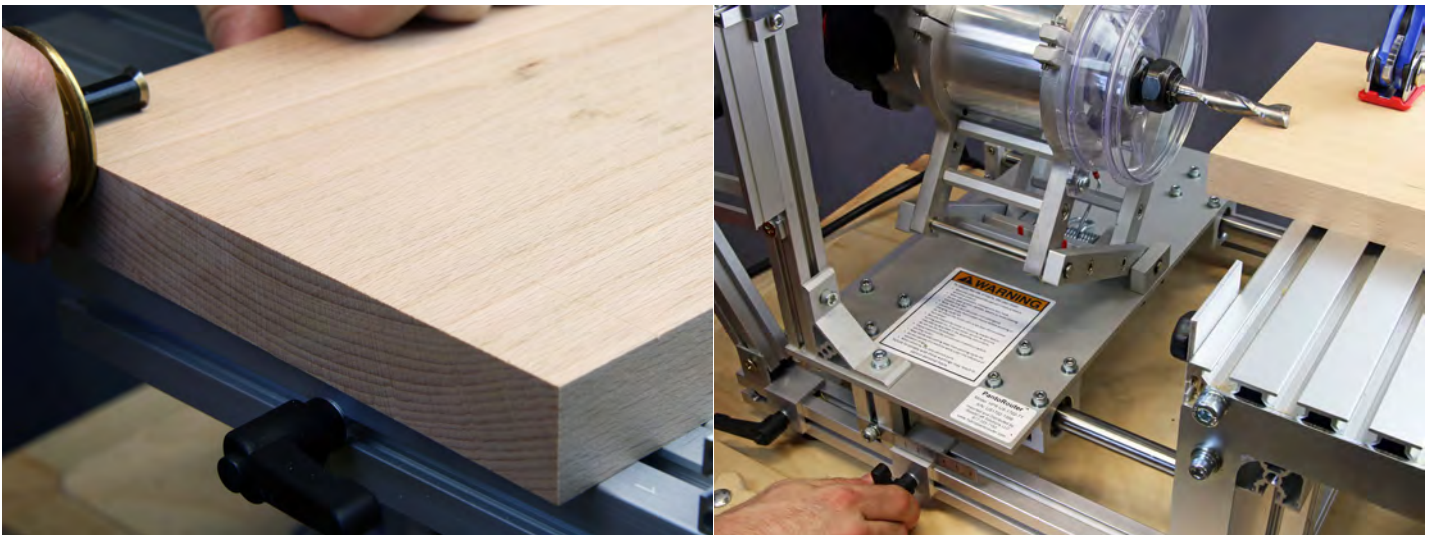

Set the depth. Just as you do with dovetails, scribe the thickness of the parts on the ends of two mating boards, and use those lines to set the bit depth, locking the stop that limits the router's forward travel. You'll also want to center the board on the table by adjusting the fence as you did for the dovetailing process.

Center the workpiece using the Centering Scale Fence. The PantoRouter fence includes a half-scale ruler, letting you simply measure any board and align the corresponding dimension on the fence with the center mark on the PantoRouter's table.



Check your clearance. Adjust the height of the template so at least half the bit clears the bottom of the workpiece before the bearing bottoms out in the slot.

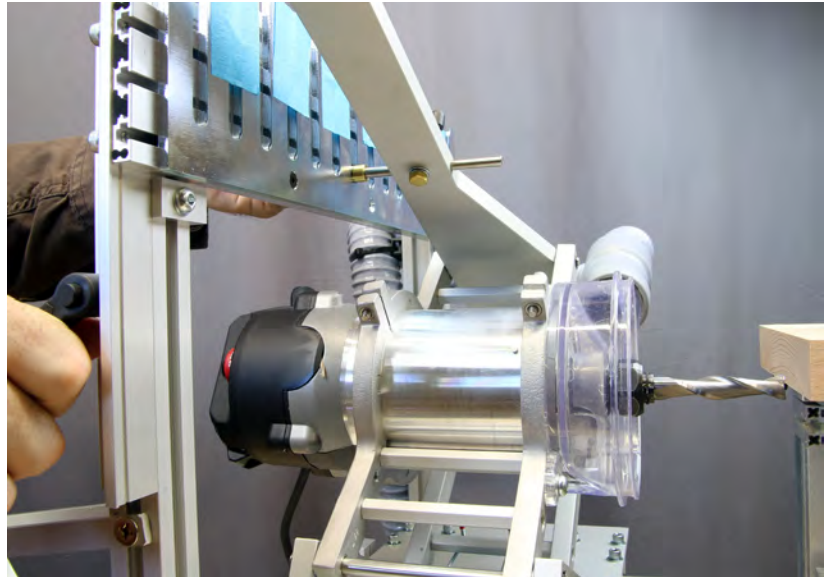

Cut the first side. You can cut a stack of parts at this point. Note how the bearing goes in every other slot. Use painter's tape to block the rest and act as a visual guide.



Another dust-free process. Paired with a powerful vac or dust collector, the Pan-toRouter's dust port grabs every chip.

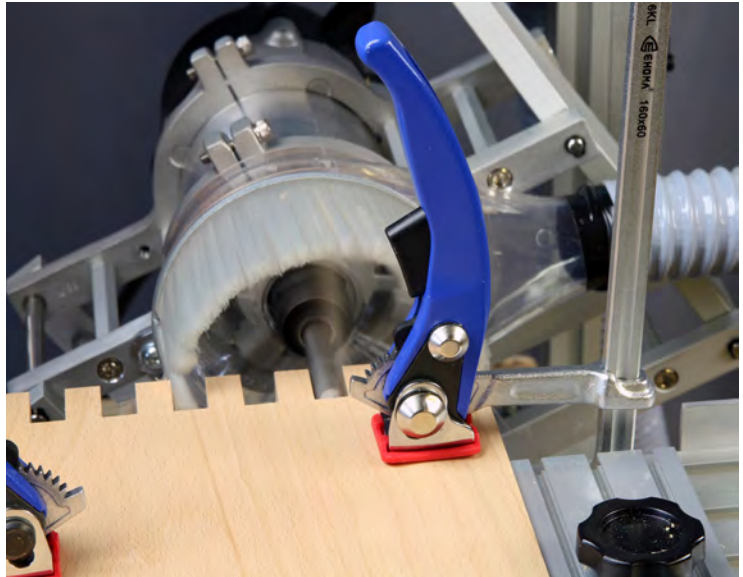

Measure the bit with dial calipers and rip or plane a spacer to the exact same width. The spacer goes between the workpiece and the fence, offsetting this half of the joint so the edges of the workpieces will line up.



Cut with confidence. Now you can cut stacks of boards for the other half of the joint, knowing the fit will be perfect.

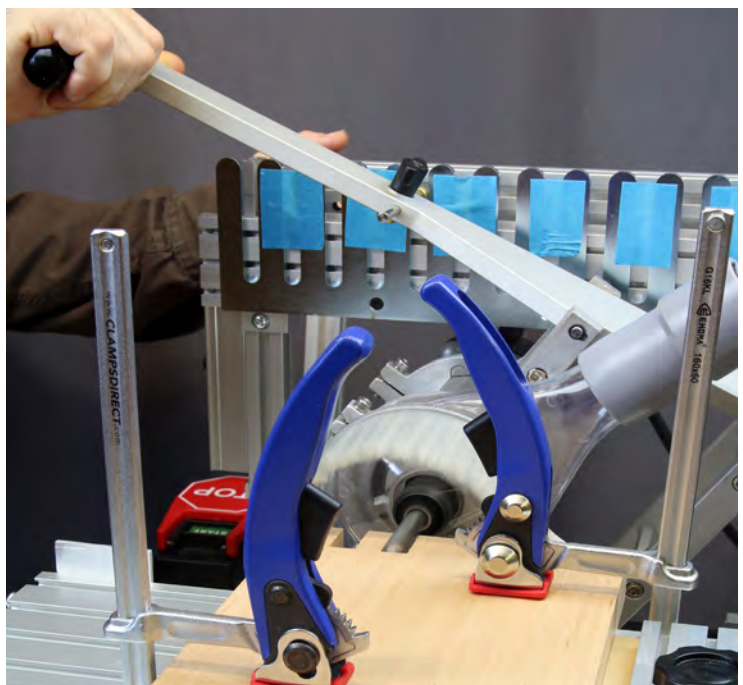

Strong and handsome. The under-rated box joint offers clean looks and excellent strength. You can cut them perfectly every time with the PantoRouter.



### **Smaller fingers are just as easy**

Only the bit changes. For 1/4-in. fingers on narrower or thinner parts, you use the same 10mm guide bearing and same template, simply changing to the 1/4-in. bit and using every slot.

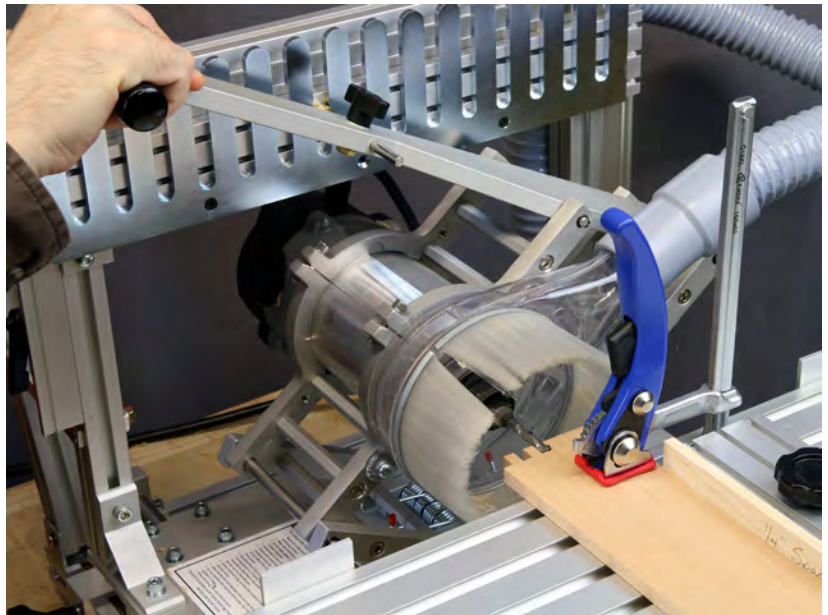

Finer look, same perfection. The 1/4-in. fingers are lovely on small boxes and trays.



WoodCraft Solutions LLC  
[www.PantoRouterUSA.com](http://www.PantoRouterUSA.com)  
[info@PantoRouterUSA.com](mailto:info@PantoRouterUSA.com)  
877-333-7150



## Variably spaced dovetails are fast and foolproof

Your PantoRouter™ package comes with 2-in-1 dovetail templates that cut both pins and tails with no change of setup, just like the templates for mortises and tenons. The template for each pin/tail is a separate unit, so they can be attached along the template holder in any array, to create a pleasing layout for workpieces up to 8 in. wide.

So get ready to make beautiful through-dovetails in minutes, with the custom spacing that is the hallmark of fine dovetails, and a perfect fit every time.

The PantoRouter can cut through-dovetails in boards up to 7/8 inch thick. Half-blind dovetails are coming soon.

Setup is straightforward. You can simply place the guide bearing against the template and the bit against your actual workpiece to plan the perfect array, and off you go. The following photos will take you through the steps, including the process for cutting asymmetrical dovetails, useful on certain boxes and drawers.

### Setup is simple

Center the workpiece using the Centering Scale Fence. The PantoRouter fence includes a half-scale ruler, letting you simply measure any board and align the corresponding dimension on the fence with the center mark on the PantoRouter's table.



Dovetailing starts with scribing. Use a marking gauge to scribe the baseline on one tails board and one pins board. We'll cut the tails first.



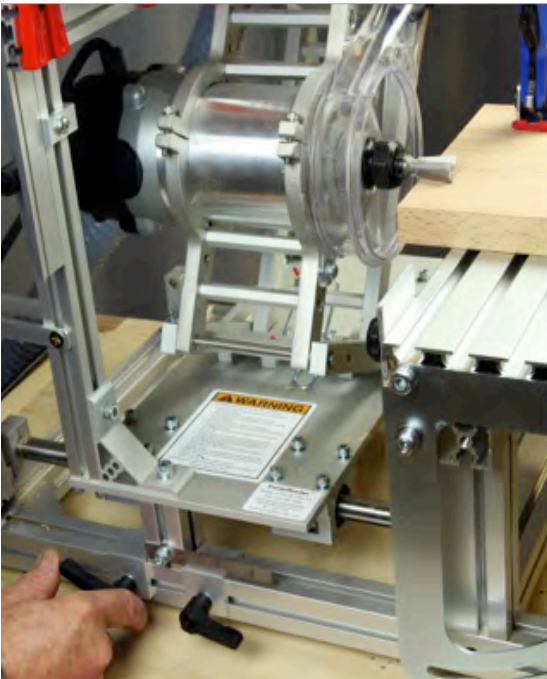

Set the depth. Load the high-quality dovetail bit supplied with your PantoRouter, align the end with your scribe line, and set the depth stop. Make sure enough of the board is overhanging the table so the bit doesn't hit it.

Set the end templates. Start by placing the guide bearing in the template groove and positioning the center of the bit over the edge of the board to create a half-pin there. With tapered tabs on their back face, the templates lock onto the template holder straight and square.

Also set the template holder height so the bit will be engaged in the template slots before it hits the wood. The bit needs to come at least half way through the workpiece in order to cut a complete tail.



Set the rest. To create a symmetrical array, center one template on the template holder (there is a mark for that), and then use the guide bearing to offset the others as shown (or just measure). This also ensures that the templates are far enough apart to allow the bearing to pass between the templates when riding the outside and cutting the pins.



### **Cut stacks of tails**

Tails are fast and easy. You can machine stacks of boards in minutes, with the PantoRouter's dust shroud grabbing every bit of waste. The bearing goes in the template's center slots for cutting tails. Push gently along each side of that slot to be sure you are making full cuts, and slow down when breaking through the bottom of the board to prevent tearout.

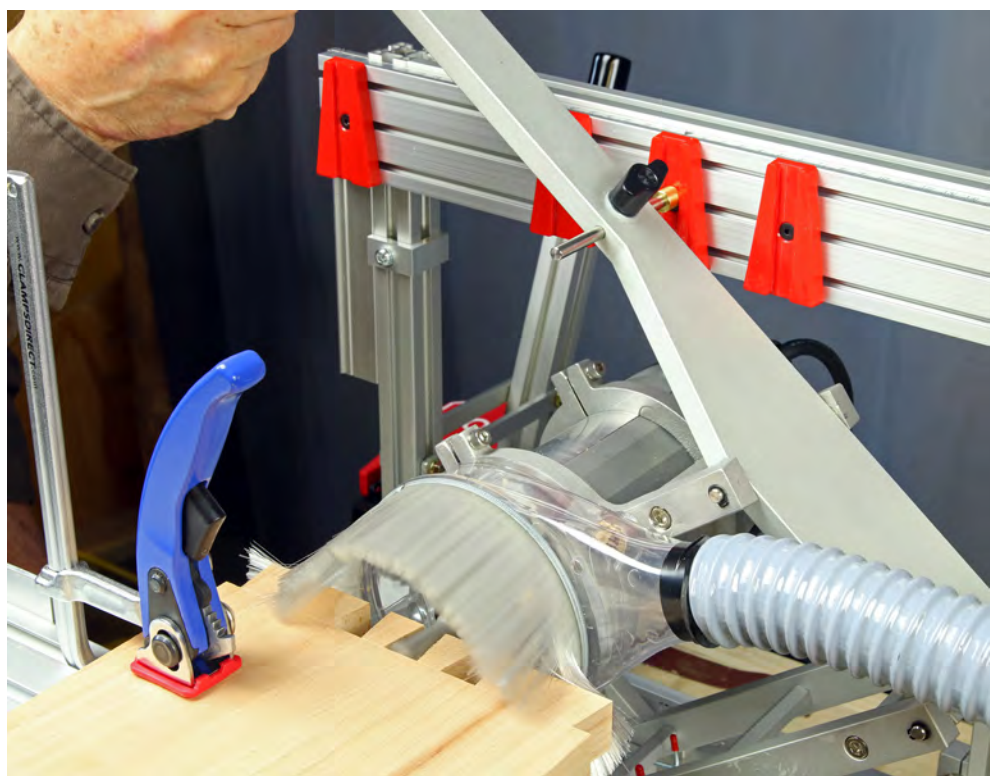

## Setup trick for perfect pins

Transfer part of the tails layout. You change the fit of the pins by moving the template holder up (looser) or down (tighter), which moves all the templates along with it. To dial in the fit from the get-go, try the following. Clamp the tails board to the top of the table as shown, and use the supplied clamps to attach a test board vertically, aligned with the board above. Then knife part of the tails layout onto the pins board.

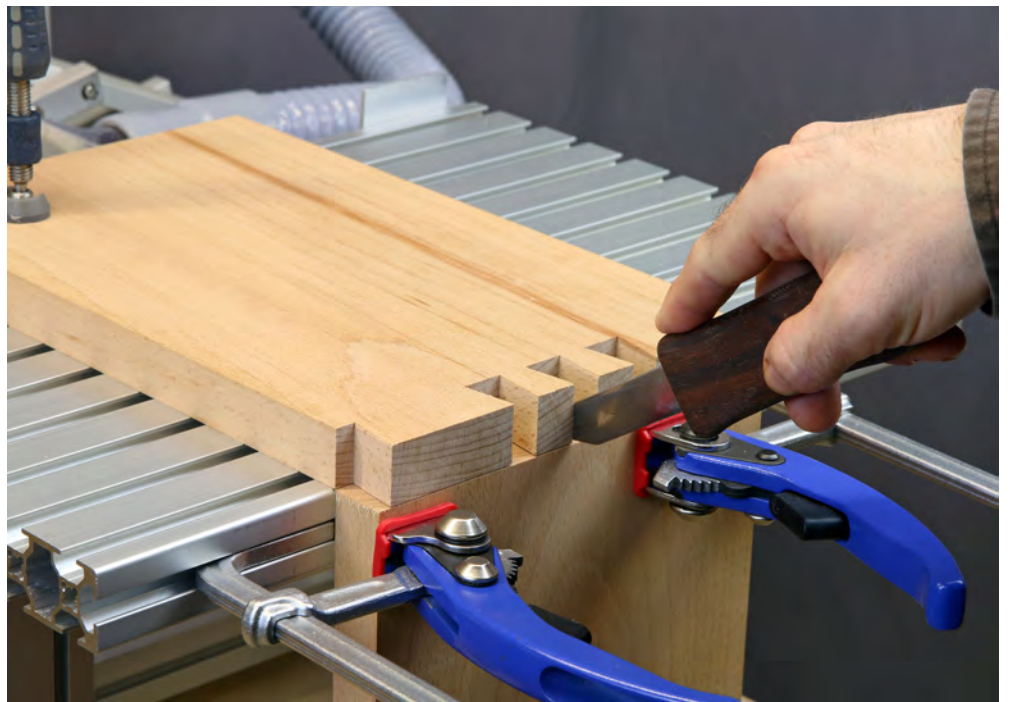

Dial in the template height. Holding the bearing against one side of a template, move the template holder up and down until the router bit is perfectly aligned with part of your pins layout. Then lock the template holder at that height.

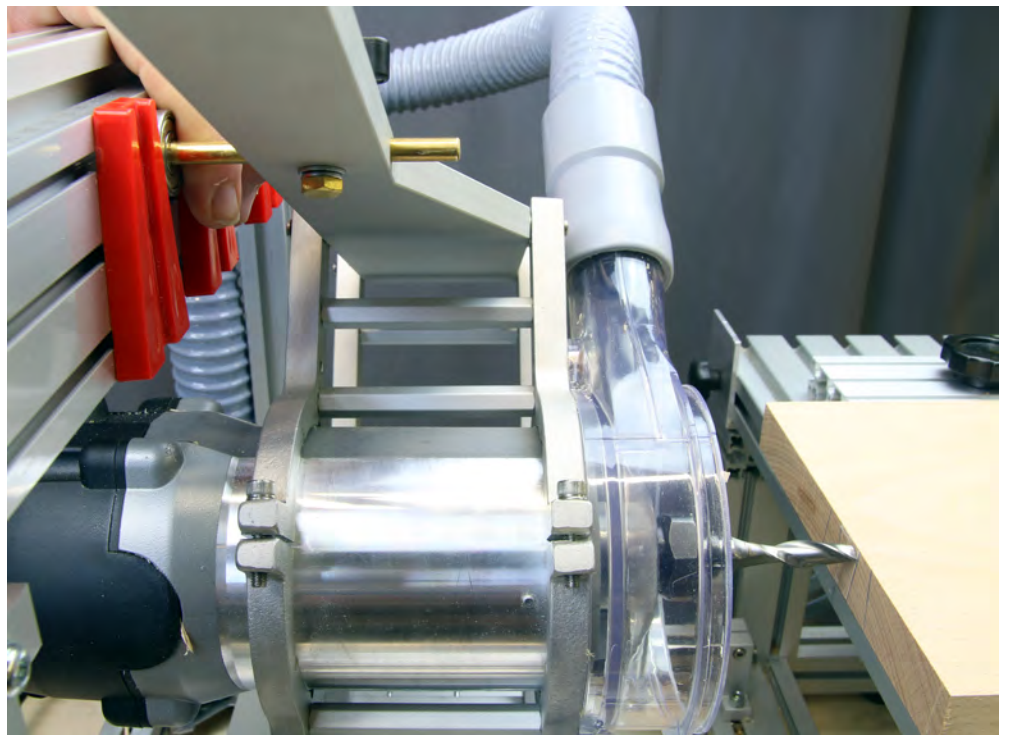

It is still important to use a test board for your first pins attempt, but the fit will be extremely close, if not dead-on. If you need to adjust the templates up or down, record the height of the template holder with a simple pencil mark.

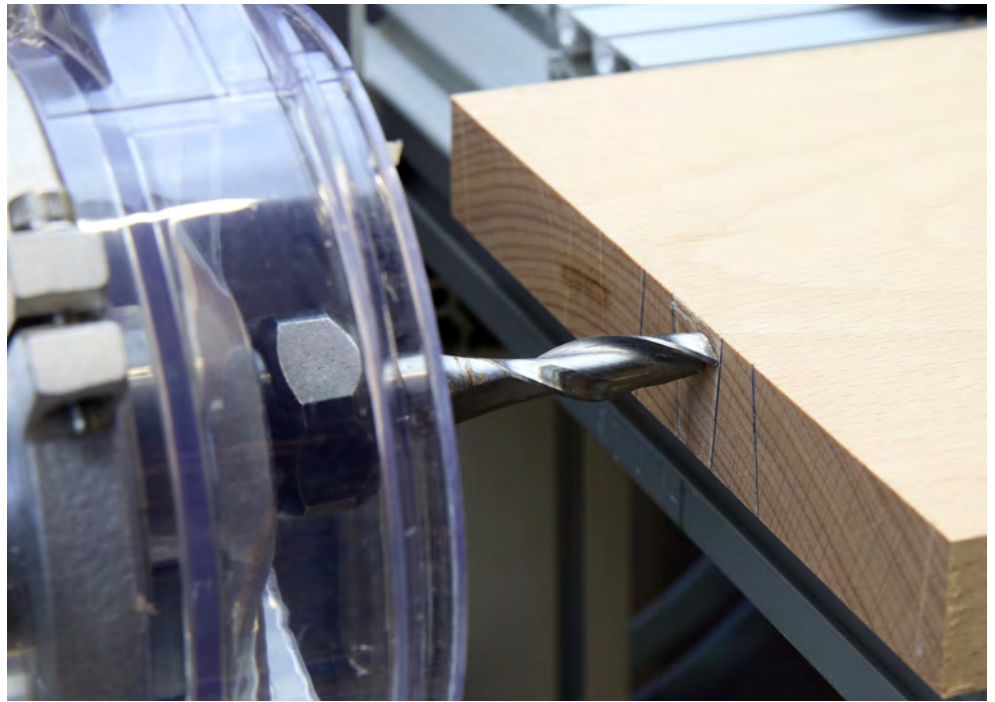

Don't forget to set the depth. Set the depth stop so the straight bit ends up right at your scribed base-line, or just past it for pins that are slightly proud.

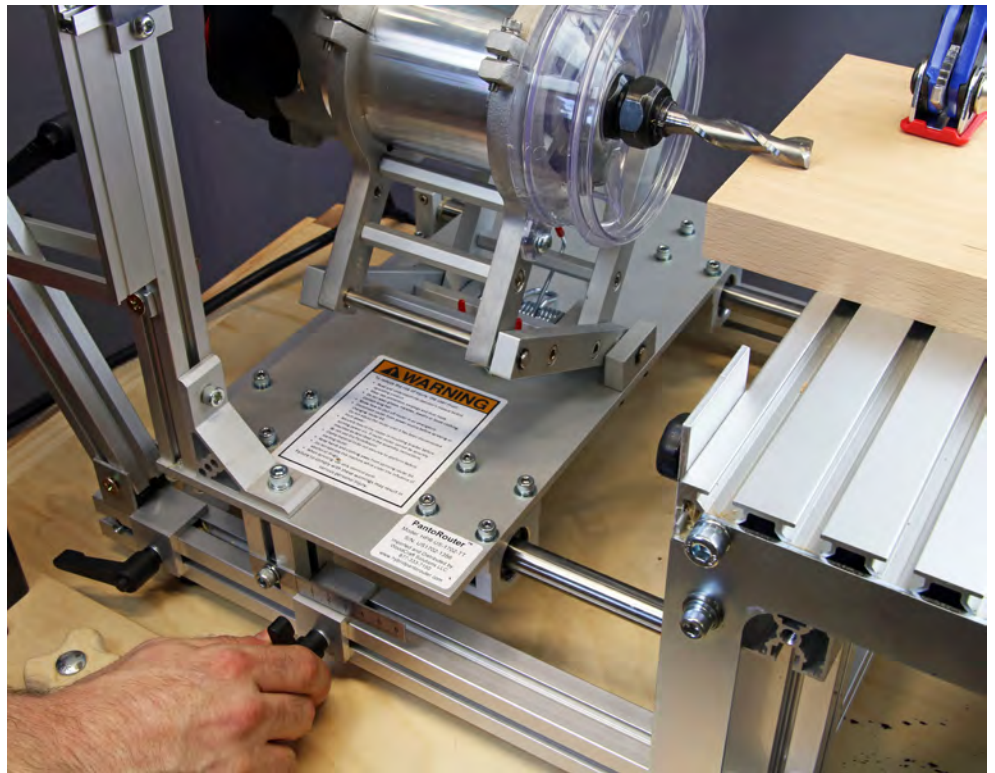

## Cut pins with confidence

Nothing changes. For perfect-fitting pins, the templates stay right where they are, and you simply ride the outside edges. The fence also stays put. Once again, slow down when breaking through the bottoms of your cuts, and tearout will be virtually eliminated.

## Proof is in the pudding

Stacks of perfect dovetails. The 2-in-1 templates ensure a perfect fit, no matter how you space the pins and tails



## Great trick for asymmetrical dovetails

For some boxes and drawers, you'll want an asymmetrical array, which will need to be reversed for opposite corners of the box. Here's how to reverse any template array.

Record it. Get the templates where you want them for one of the joints, and use a long folded piece of paper as a story stick for marking the centers of the templates, as well as the center of the template holder. Then cuts pins and tails as usual.



Reverse the array. To create the same array in reverse, just unfold the paper and extend your marks a little. Now you can fold and flip your paper ruler, and use the marks to re-center the array on the template holder and reset all of the templates.

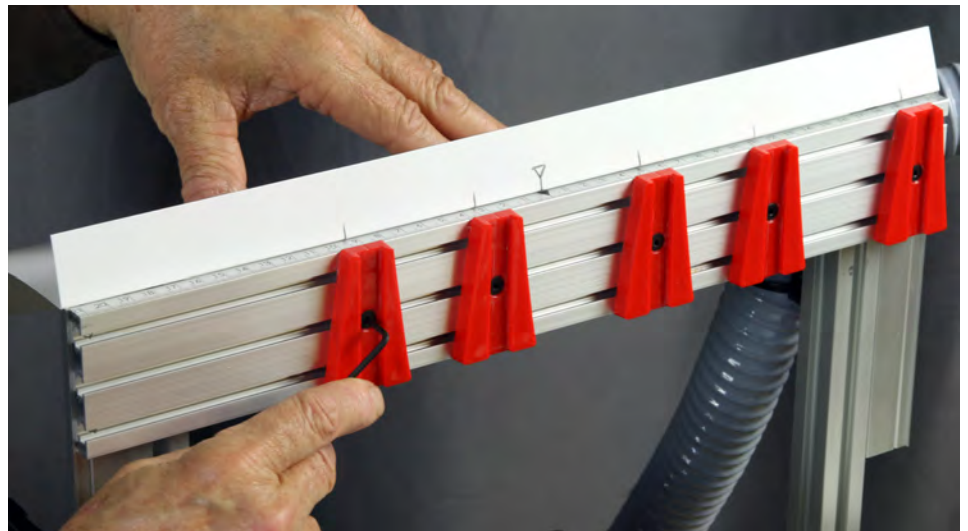

**Happy  
PantoRouting!**

**WoodCraft Solutions LLC**  
[www.PantoRouterUSA.com](http://www.PantoRouterUSA.com)  
[info@PantoRouterUSA.com](mailto:info@PantoRouterUSA.com)  
877-333-7150



# PantoRouter®

## How-To Guide

**Mortise & Tenon, Box Joints  
Dovetails, and Much More!**



Copyright 2019 - WoodCraft Solutions LLC

Imported and Distributed in North and South America,

New Zealand and Australia by

WoodCraft Solutions LLC

[www.PantoRouter.com](http://www.PantoRouter.com)

[info@PantoRouter.com](mailto:info@PantoRouter.com)

+1-877-333-7150





# TABLE OF CONTENTS

<b>MORTISE AND TENON</b>	<b>4</b>
<b>SETUP</b>	<b>4</b>
<b>MORTISES FIRST</b>	<b>5</b>
<b>TENONS</b>	<b>8</b>
<b>MULTIPLE M&amp;T</b>	<b>9</b>
<b>TENON THICKNESS CHART</b>	<b>11</b>
<b>BOX JOINTS</b>	<b>12</b>
<b>SETUP</b>	<b>12</b>
<b>CUTTING 1/2" AND 1/4" BOX JOINTS</b>	<b>13</b>
<b>VARIABLY SPACED DOVETAILS</b>	<b>16</b>
<b>SETUP</b>	<b>16</b>
<b>TAILS</b>	<b>18</b>
<b>PINS</b>	<b>19</b>
<b>ASYMMETRICAL DOVETAILS</b>	<b>21</b>
<b>LIMITED EDITION TEMPLATES &amp; ACCESSORIES</b>	<b>23</b>
<b>DIAMOND</b>	<b>23</b>
<b>BOWTIE</b>	<b>23</b>
<b>MONSTER M&amp;T</b>	<b>23</b>
<b>DOWELS</b>	<b>24</b>

# Matching mortises and tenons in minutes

Copyright 2019 WoodCraft Solutions LLC

With its 2-to-1 movement and 2-in-1 templates, the PantoRouter™ makes faster, better-fitting mortises and tenons than any other method. The templates are the key, capturing the guide bearing in their center slot to make the mortise, and then guiding the guide bearing around the outside for foolproof tenons too. A tapered guide surface allows incredibly fine adjustments to tenon fit, for perfect results right off the machine.

The standard package includes an array of templates for various joint sizes and orientations, the Pro-Pack Package has even more, and all are available à la carte from our online store.

The genius of the system doesn't stop at the templates. Setting up the template holder, fences and depth stop is just as fast and easy. And once they are set, you can make stacks of joints in minutes, dead-accurate and dust-free thanks to our patent dust-collection attachment.

Follow the process shown here, and you'll make better joints than ever before, in a fraction of the time.

## Setup steps

**Choose your template.** The thickness of your mortise is determined by the size of the router bit used to cut them. By changing the bit and guide bearing, you can make the corresponding tenon, so all that matters here is length (the 2-to-1 pantograph ratio means joints are always half the length of a given template). All templates have tabs on the back that keep them parallel with the template holder, and small nuts that slide into T-slots.

**Center the template side to side.** Insert a 6mm round guide bearing shaft through the template and through the center hole in the template holder. That's all there is to it! Your template is now centered.

*Note: Older template holders don't have the centering hole so the following procedure is used to center the template:*

*Insert the pointed centering jig in the router chuck. Then insert the 6mm round guide bearing shaft into the hole in the center of the template and move the template side to side until the point of the centering jig is aligned with the table's centerline. Lock the template in that position and it's centered too. Older templates require the tapered shaft for centering since their center hole is a bit smaller than newer versions.*



**Center the template vertically.** This step is just as easy. Once you've properly set the thickness gage below the template holder (see the assembly and setup instructions for the PantoRouter), all you need to do is place a cutoff from one of your workpieces, or the workpiece itself, between the template holder and thickness gage to know you have centered the template and router bit on the stock. Lock the template holder in that position.



**Measure the tenon piece to set the fence.** Even though you'll be mortising first, use the tenon piece here if your M&T joint will be on the end of your workpiece. Measure the width then adjust the fence to that same dimension. The inner ruler on the fence is half-scale, making the fence self-centering. *To avoid pulling the fence out of square, always tighten the back knob first, as shown, before tightening the knob on the fence.*



## Mortises first

**Insert the mortise guide bearing.** Choose the 10mm guide bearing and insert it into the mortise slot of the template. Also, insert the bit for the mortise you are cutting. See the reference chart later in this guide.



**Clamps and clamp helpers.** The standard clamps work in most situations, but for mortising, make simple clamp helpers like the one shown to get pressure where you need it. Avoid clamping directly over the area to be mortised, as the clamp could end up cracking the mortise wall.

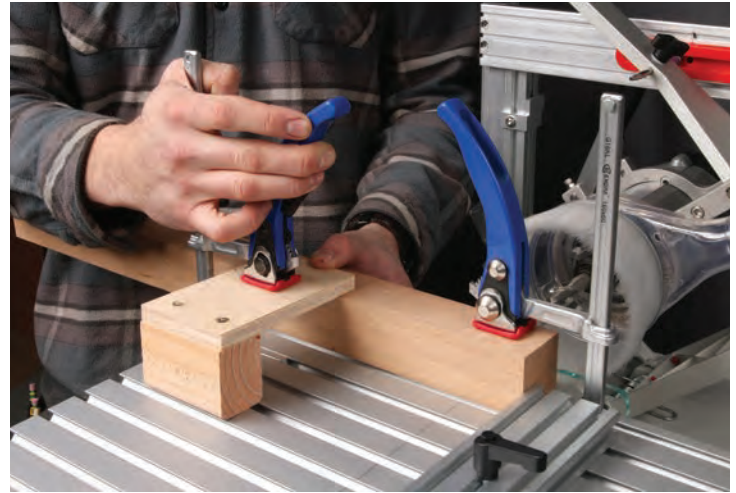

**Set the depth.** The excellent solid carbide bits included with your PantoRouter cut crisp, clean mortises. Simply touch the bit to the workpiece and slide the depth stop just past the length of the tenon you'll cut next. We want a little room for excess glue at the bottom of the mortise. About an 1/8" or 3mm is plenty.

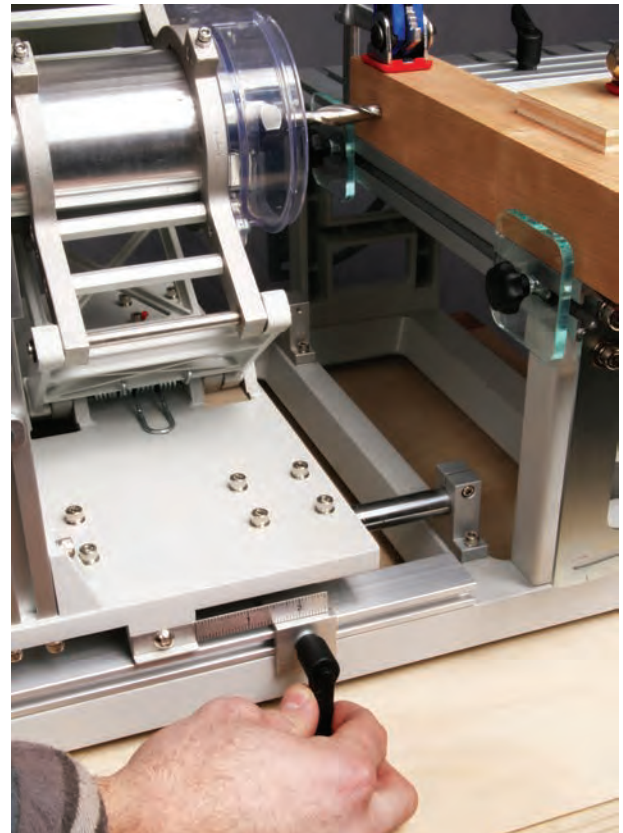

**Dust shroud goes back on.** The highly effective and convenient dust collection hood has a brush-style shroud that comes off easily for setup and goes back on just as quickly.

*Note: If the brush ever gets smushed, go to our website in the Support section and find the Tech Tip called "Bad Hair Day" for an easy way to straighten the bristles. [www.PantoRouter.com](http://www.PantoRouter.com)*

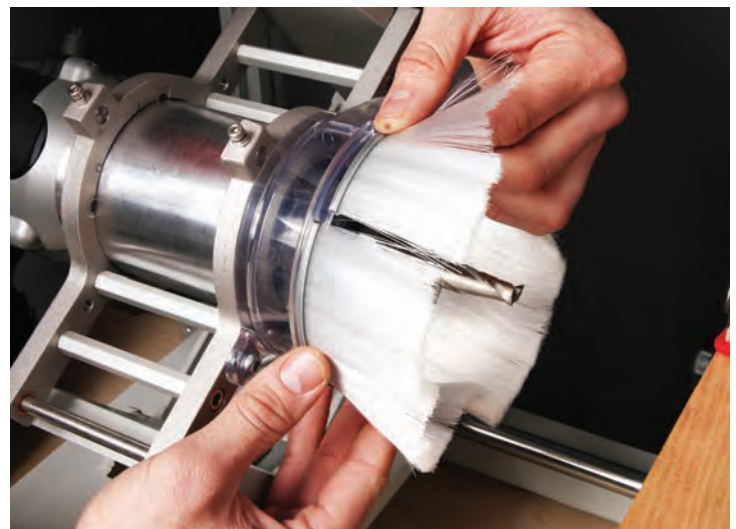

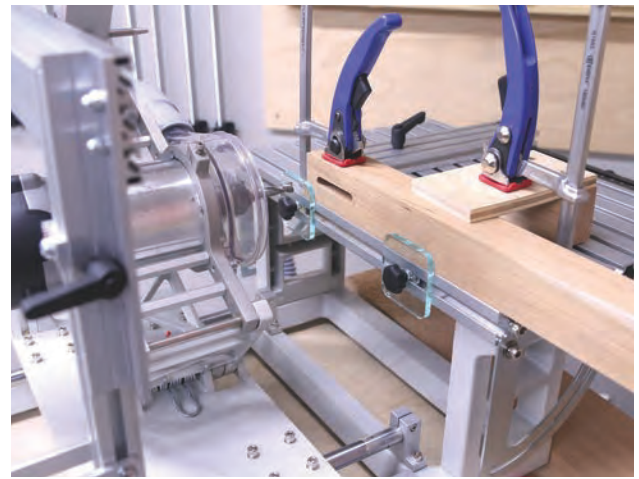
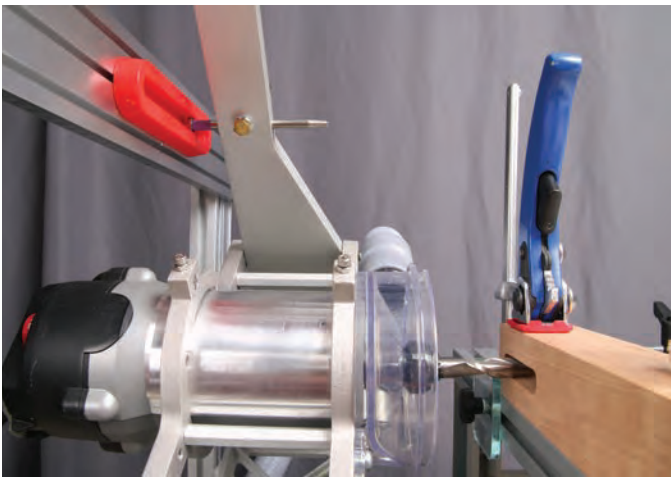

**Mortising is fast and foolproof.** Take shallow passes, moving the router back and forth with one hand and gently pushing forward with the other, until the depth stop bottoms out. That's it! We've removed the dust shroud for these photos but you'll definitely want to keep it on for mortise and tenon work.

*Note the two Fence/Stops on the table that align the workpiece to the front of the table. They're acrylic or plastic to make it a little easier on the bit if one gets accidentally nicked. Once the workpiece is clamped in place the front stops can easily be slid out of the way.*

**Magic in the mortise slot.** In the ends of the mortise slots there are three steps to make the mortise a little longer than the tenon if you prefer a little wiggle room for adjustment during glue-up. Following the bottom of the mortise pocket with your guide bearing makes a perfect fitting mortise and tenon joint, which is always a good idea for through mortises. The second and third steps allow a little more room at the ends of the tenons. Both ends of the mortise are end grain so there's much less strength in that part of the joint than the glued side grain so a little extra room doesn't significantly weaken the joint.

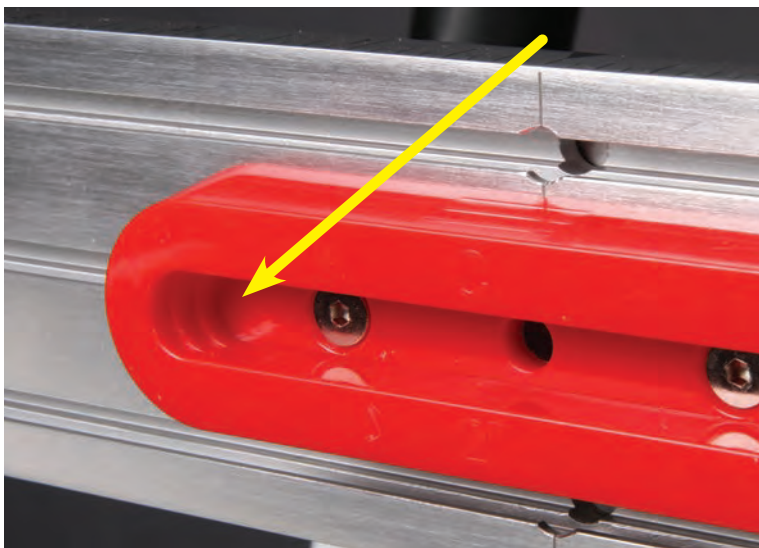

## Tenons second

Trace the outside of the template for tenons. You might be able to use the same bit for tenons as you used for mortising. Check the chart later in this guide to find the best combination. Also, push the guide bearing to the back edge of the template for your first tenon attempt.

The template is thicker toward the back so the tenon cut using that position will be thicker as well, usually too thick for the mortise, but it's the best place to start.

*Note: While some M&T sizes have several possible combinations, it's best to use the largest bit and bearing combination listed on the chart for the desired tenon thickness.*

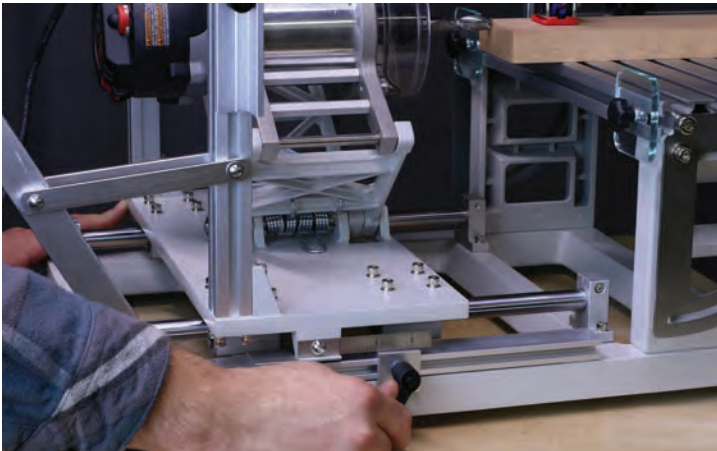

**Reset the depth stop.** Touch the end of the workpiece with the bit then set the depth as before but the tenon must be slightly shorter than the mortise is deep.

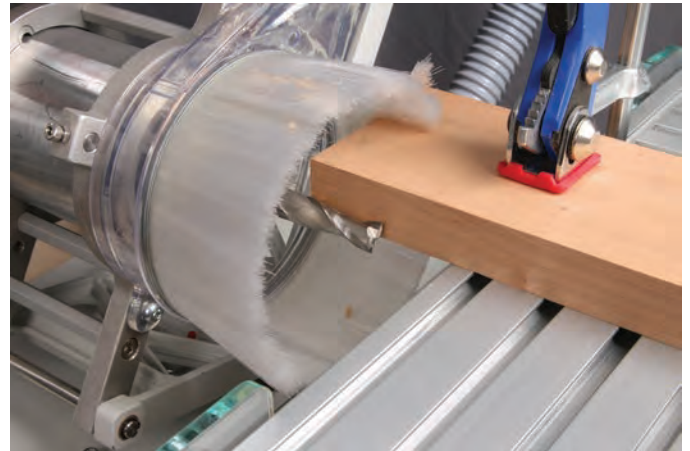

**Safety check.** Check that you've extended the workpiece far enough so the bit will clear the table at its full cutting depth.



**Tenoning is just as fast and foolproof.** Use climb cuts for a clean shoulder, working your way deeper and farther down the tenon as you go, until the bearing is riding the template and the depth stop is bottomed out.



**Control over the router.** The mechanical advantage ratio is about 2.5:1 at the handle, so you'll have perfect control, even though you are climb-cutting all the way.

**Check the fit.** The tenon could be just a bit fat at this point.

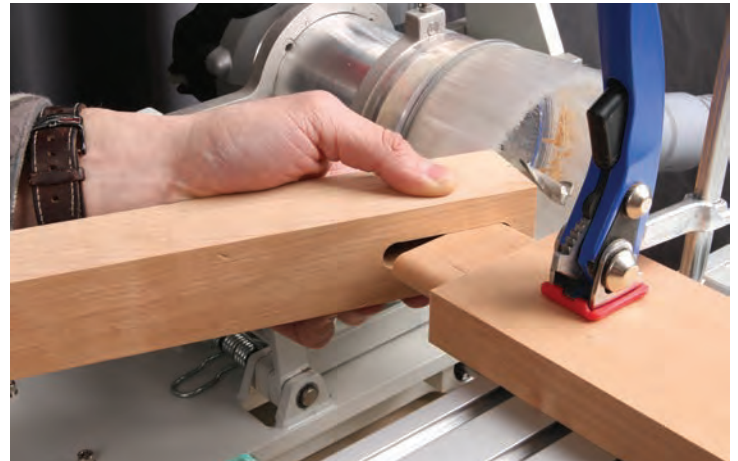

**Adjustments are amazingly easy.** The templates have a slightly tapered outer edge, so moving the guide bearing outward (down the taper) slightly adjusts the fit by a few thousandths of an inch. Once you dial in the fit, you can crank out piles of cleanly cut, deadly-accurate tenons in minutes.

Once you've identified the best fit for your bit and guide bearing, note the position of the guide bearing relative to the three index marks so you can quickly repeat that size M&T the next time you need it for your work.

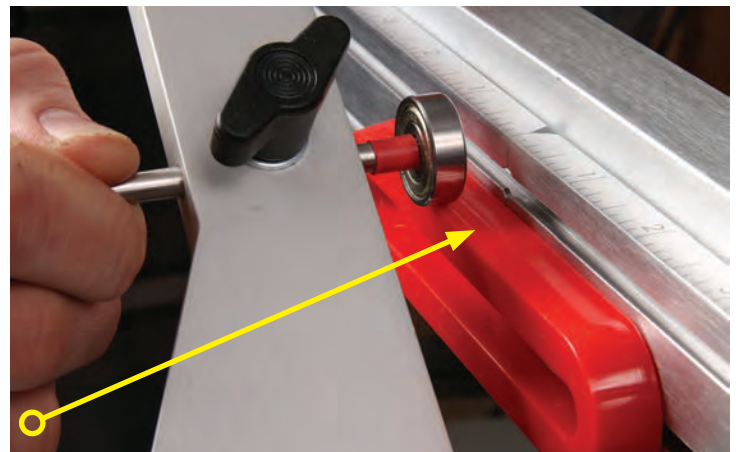

## Multiple tenons are just as easy.

**For wide workpieces, combine templates.** Use a square and the scale on top of the template holder to align the templates. Make sure to leave room between them for the guide bearing to pass through (remember the 2-to-1 scale again as you select your guide bearing and space the templates).





**Make a test run.** To be sure the mortises and tenons will fall in the right place, cut mortises in some scrap.



**Two mortises are almost as fast as one.** You just need to stop to pull the guide bearing out of the center slot of one template and put it into the other.

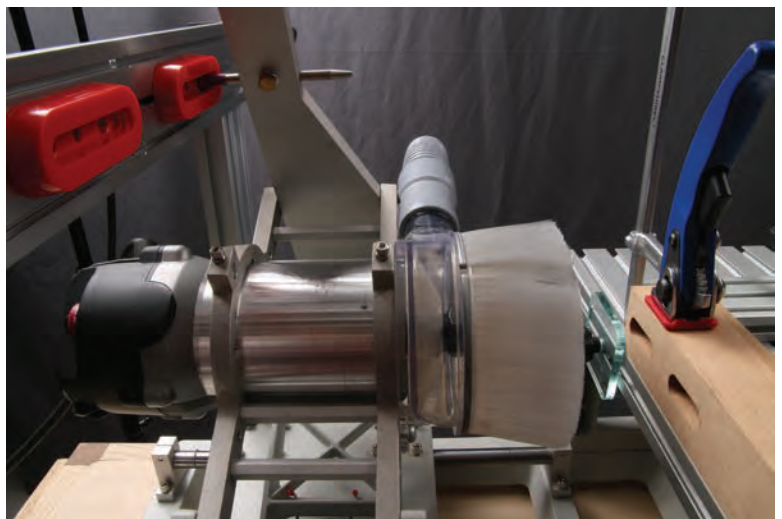

**Two tenons in one minute.** Like before, use climb cuts to make a series of shallow passes, working your way toward full depth, and adjust the guide bearing outward, down the taper to dial-in the fit.

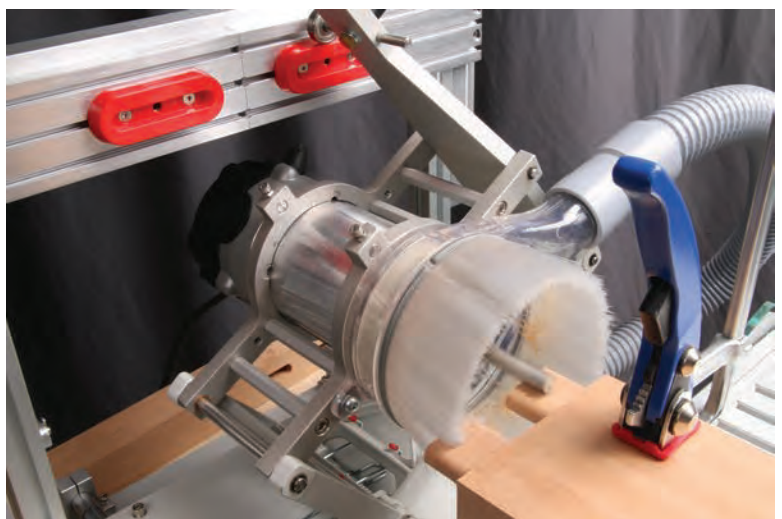



Perfection. You will get perfect alignment and a perfect press-fit right off the machine.

## Mortise and tenon joinery examples

The mortise and tenon are mirror images so position the workpieces with indexing against the fence accordingly. Cut the mortise first then adjust the fit of the tenon. Move the guide bearing down the tapered template, away from the template holder, to make the tenon smaller.

Notice in the combinations for each size below, the 1/2" bit is possible for every size. It's always a good idea to use a larger bit when possible and 1/2" is the sweet spot for ease and quality of cut for most sizes.

		GB	Bit
Tenon Size	1/8"	6	1/2
		10	1/2
	1/4"	22	3/4
		35	1
	3/8"	10	3/8
		15	1/2
	1/2"	10	1/4
		15	3/8
		22	1/2
		35	3/4
	3/4"	48	1
		22	1/4
		35	1/2
	1"	48	3/4
		35	1/4
		48	1/2



It's best to use larger guide bearings and bits where possible.  
 The 1/2" spiral upcut bit works with every size.  
 The 35mm (yellow) and 48mm (orange) guide bearings come with the Monster Set along with 3/4" and 1" straight cut bits.

## Box joints in minutes, with no fitting

Even easier than it cranks out mortise and tenon and dovetails, the PantoRouter uses a single steel template to make immaculate box joints in two sizes, with perfect joints right off the machine—no sample boards or fitting required. For 1/2-in. fingers, use the 1/2-in. bit supplied and skip every other slot in the template. For 1/4-in. box joints on smaller projects, use the smaller bit and every slot on the template. The 10mm guide bearing is always the same.

There isn't much more to say, other than the fact that the template fingers are fixed, meaning only certain board widths will give perfect fingers on the ends of a joint. Stock that's a multiple of 1/4" or 1/2" will have full fingers on the ends but if you don't mind partial fingers, you can use workpieces of any width. Also, the tall box joint template lets you cut joints in stock up to a hefty 1-1/2 in. thick.

Soon you will be finding all sorts of reasons to use these clean-looking box joints, from shop trays and cabinet drawers to quick gifts for friends and family.

### Cut one side of the joint

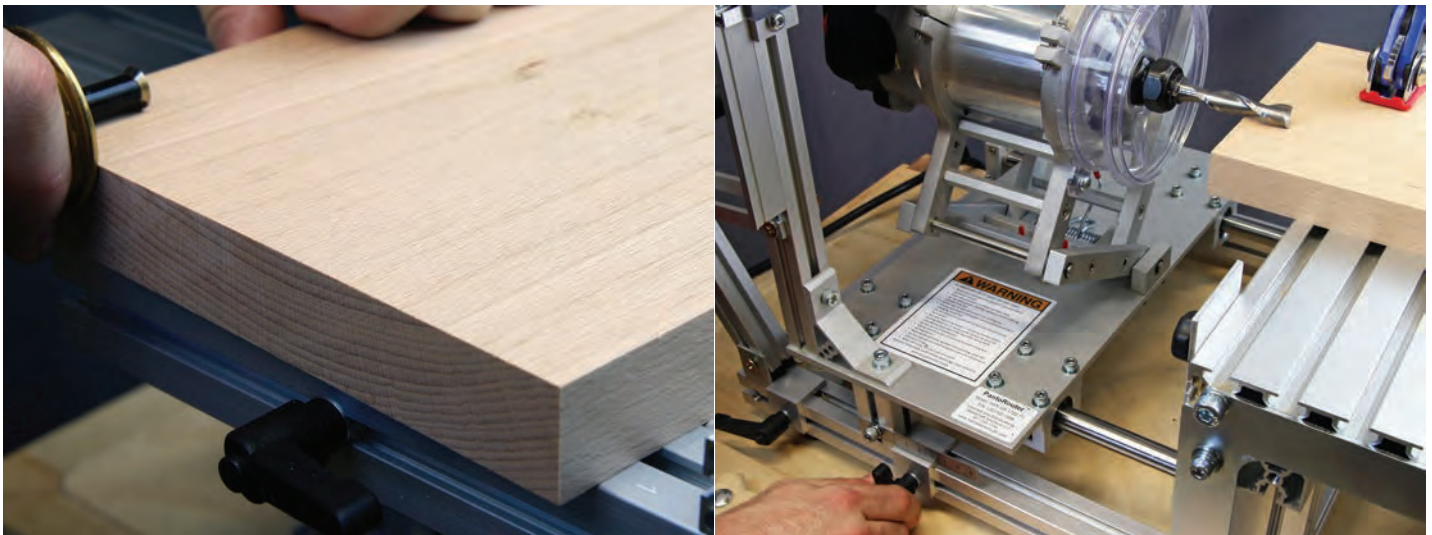

**Set the depth.** Just as you do with dovetails, scribe the thickness of the parts on the ends of two mating boards, and use those lines to set the bit depth, locking the depth stop that limits the router's forward travel. You'll also want to center the board on the table by adjusting the fence as you do for mortise and tenon and the dovetailing process.

**Center the workpiece using the Centering Scale Fence.** The PantoRouter fence includes a half-scale ruler, letting you simply measure any board and align the corresponding dimension on the fence with the center mark on the PantoRouter's table.



**Check your clearance.** Adjust the height of the template so at least half the bit clears the bottom of the workpiece before the bearing bottoms out in the slot.

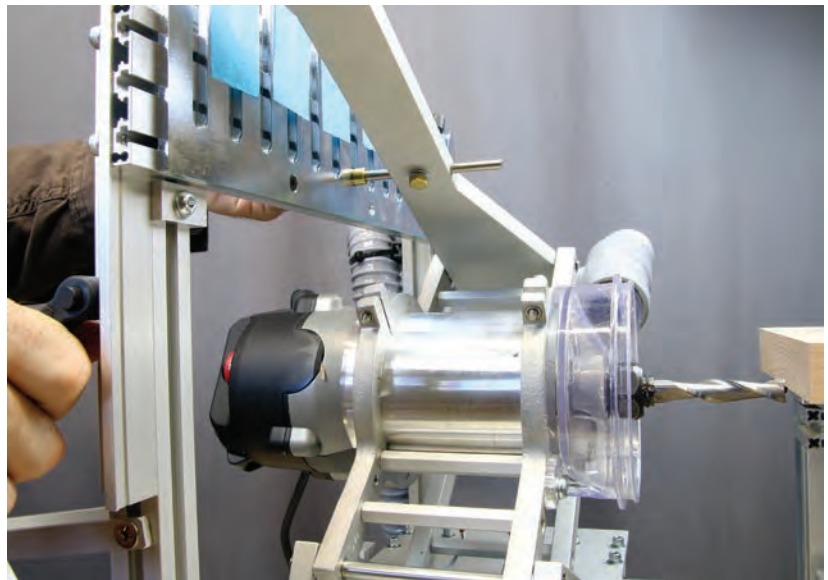

**Cut the first side.** You can cut a stack of parts at this point. Note how the bearing goes in every other slot. Use painter's tape to block the rest and act as a visual guide.

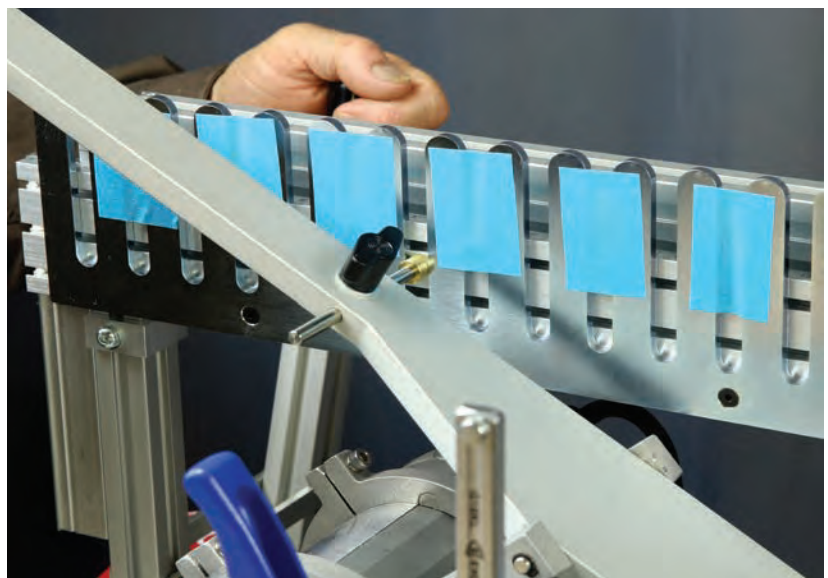

**Another dust-free process.** Paired with a powerful vac or dust collector, the PantoRouter's dust collection system grabs every chip.

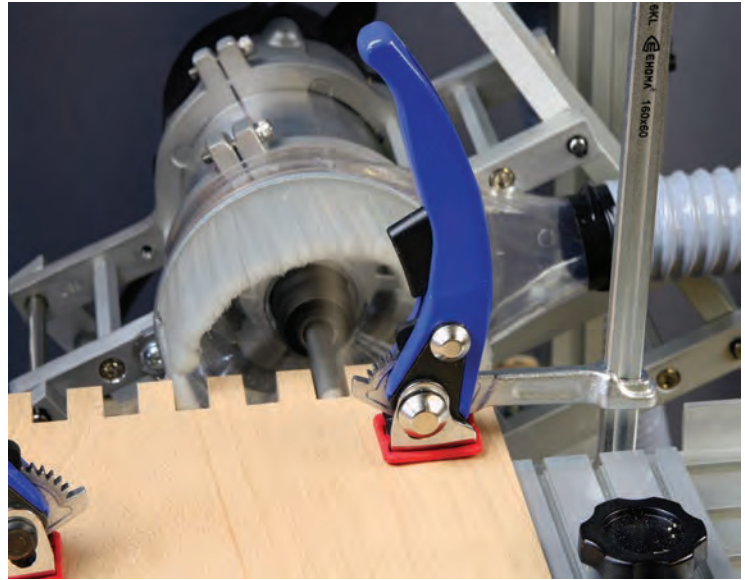

Measure the bit with dial calipers and rip or plane a spacer to the exact same width. The spacer goes between the workpiece and the fence, offsetting this half of the joint so the edges of the workpieces will line up.



**Cut with confidence.** Now you can cut stacks of boards for the other half of the joint, knowing the fit will be perfect.

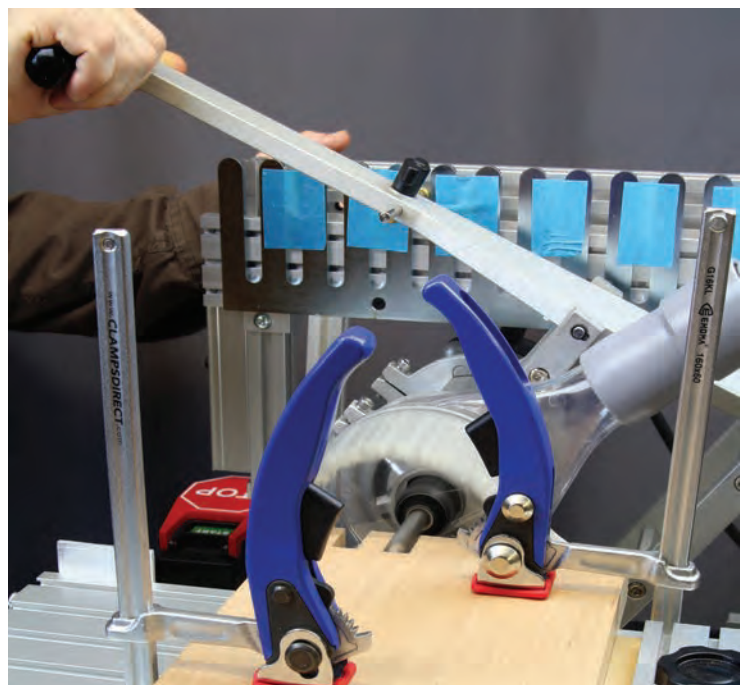

**Strong and handsome.** The underrated box joint offers clean looks and excellent strength. You can cut them perfectly every time with the PantoRouter™.



### **Smaller fingers are just as easy**

**Only the bit changes.** For 1/4-in. fingers on narrower or thinner parts, you use the same 10mm guide bearing and same template, simply changing to the 1/4-in. bit and using every slot.

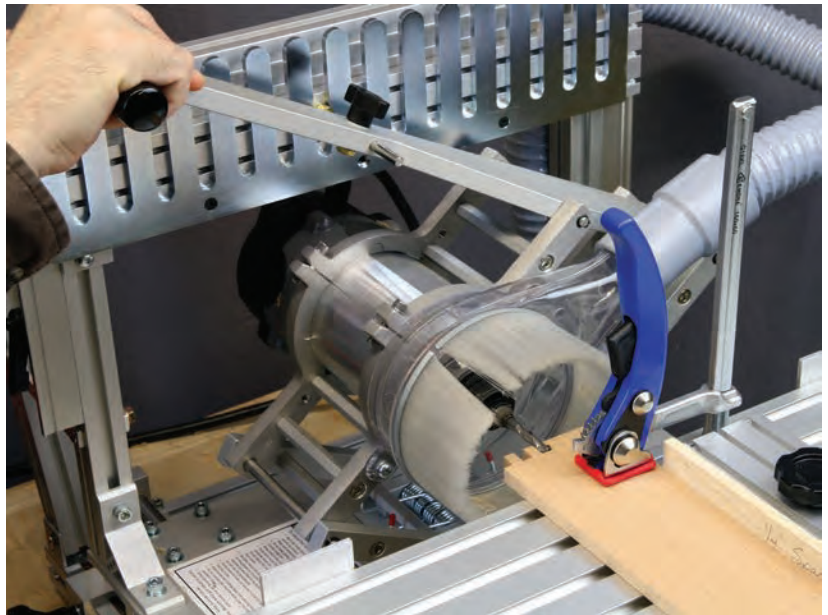

**Finer look, same perfection.** The 1/4-in. fingers are lovely on small boxes and trays.



# Variably spaced dovetails are fast and foolproof

Your PantoRouter™ package comes with 2-in-1 dovetail templates that cut both pins and tails with no change of setup, just like the templates for mortises and tenons. The template for each pin/tail is a separate unit, so they can be attached along the template holder in any array, to create a pleasing layout for workpieces up to 8 in. wide.

So get ready to make beautiful through-dovetails in minutes, with the custom spacing that is the hallmark of fine dovetails, and a perfect fit every time.

The PantoRouter can cut through-dovetails in boards up to 1¼ inch thick.

Setup is straightforward. You can simply place the guide bearing against the template and the bit against your actual workpiece to plan the perfect array, and off you go. The following photos will take you through the steps, including the process for cutting asymmetrical dovetails, useful on certain boxes and drawers.

## Setup is simple

Center the workpiece using the Centering Scale Fence. The PantoRouter fence includes a half-scale ruler, letting you simply measure any board and align the corresponding dimension on the fence with the center mark on the PantoRouter's table.



Dovetailing starts with scribing. Use a marking gauge to scribe the baseline on one tails board and one pins board. Always cut the tails first.



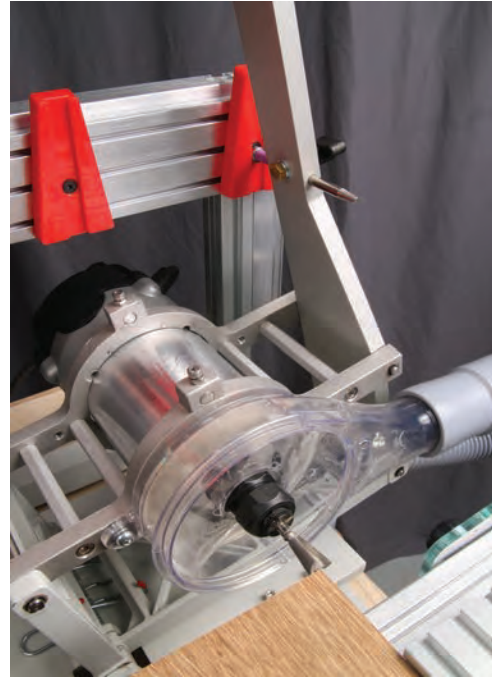
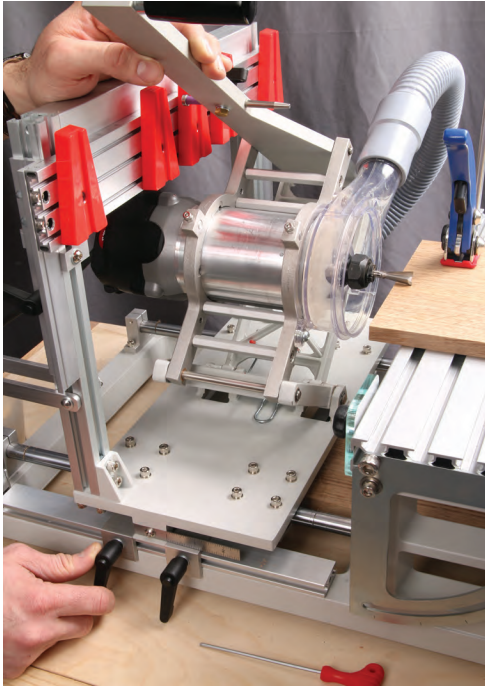

**Set the depth.** Load the high-quality dovetail bit supplied with your PantoRouter or an 8° bit of your own, align the end with your scribe line, and set both the front and rear depth stops. Make sure enough of the board is overhanging the table so the bit doesn't hit it.

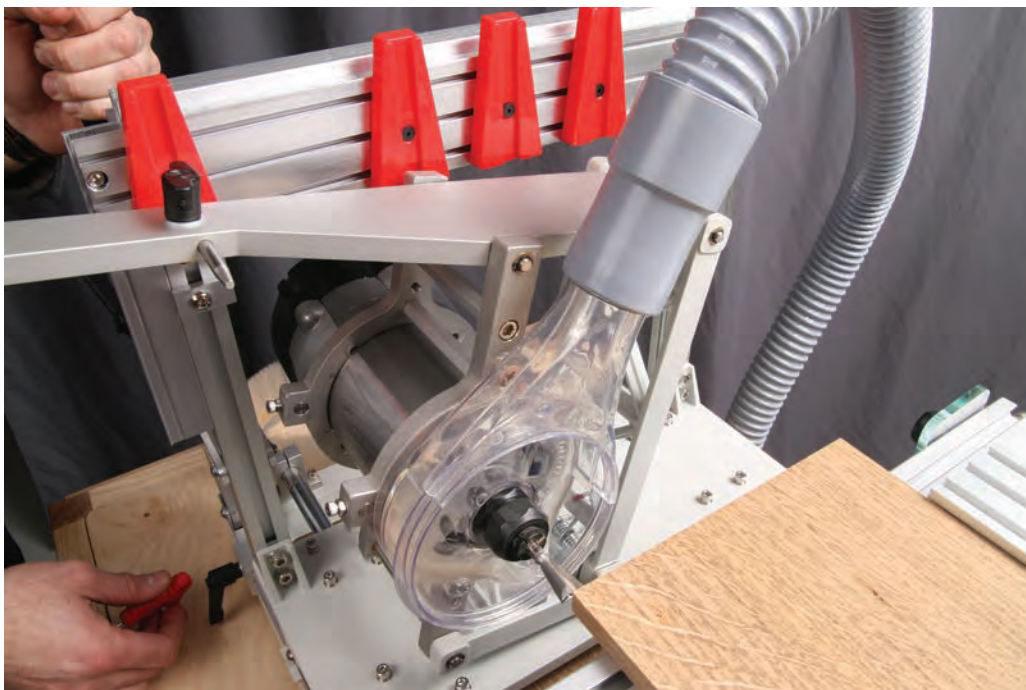

**Set the end templates.** Start by placing the guide bearing in the template groove and positioning the center of the bit over the edge of the board to create a half-pin there. With tapered tabs on their back face, the templates lock onto the template holder straight and square.

Also set the template holder height so the bit will be engaged in the template slots before it hits the wood. The bit needs to come at least half way through the workpiece in order to cut a complete tail.



**Set the rest.** To create a symmetrical array, center one template on the template holder align the template center splines on the backs of the templates to the scale on top of the template holder.

Be sure the templates are far enough apart to allow the bearing to pass between the templates when riding the outside of the templates to cut the pins.

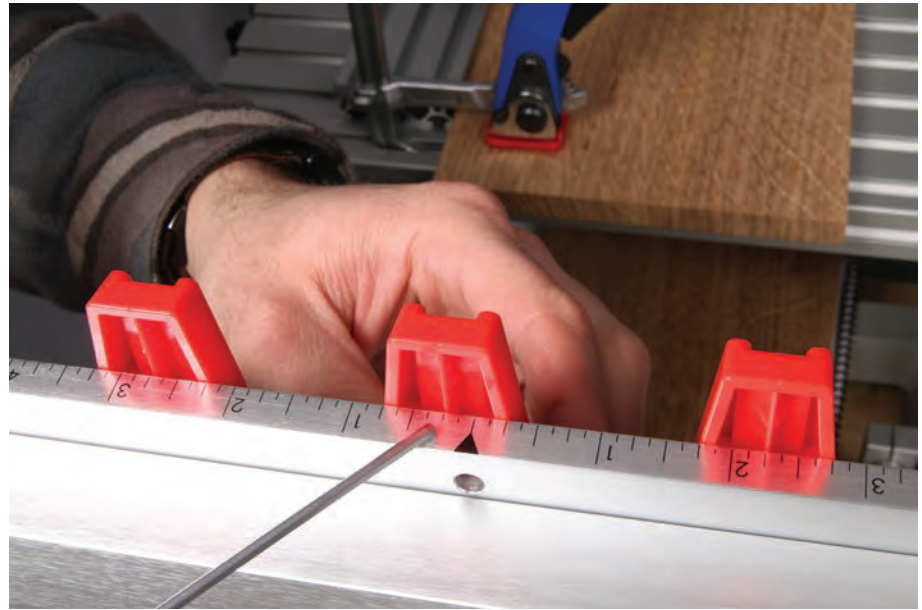

## Cut stacks of tails

**Tails are fast and easy.** You can machine stacks of boards in minutes, with the PantoRouter's dust shroud grabbing every bit of waste. The bearing goes in the template's center slots for cutting tails. Follow gently along each side of that slot to be sure you are making full cuts, and slow down when breaking through the bottom of the board to prevent tearout.

Gentle and even pressure is the key to making consistently accurate dovetails with the PantoRouter™.

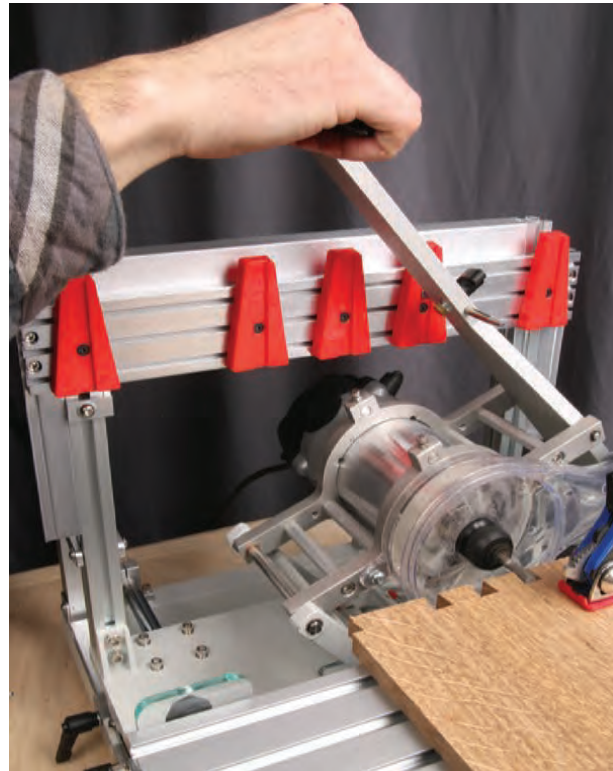

## Setup trick for perfect pins

**Transfer the tails layout.** You change the fit of the pins by moving the template holder up (looser) or down (tighter), which moves all the templates along with it. To dial in the fit from the get-go, try the following. Clamp the tails board to the top of the table as shown, and use the supplied clamps to attach a test board vertically, aligned with the board above. Then knife part or all of the tails layout onto the pins board test piece.

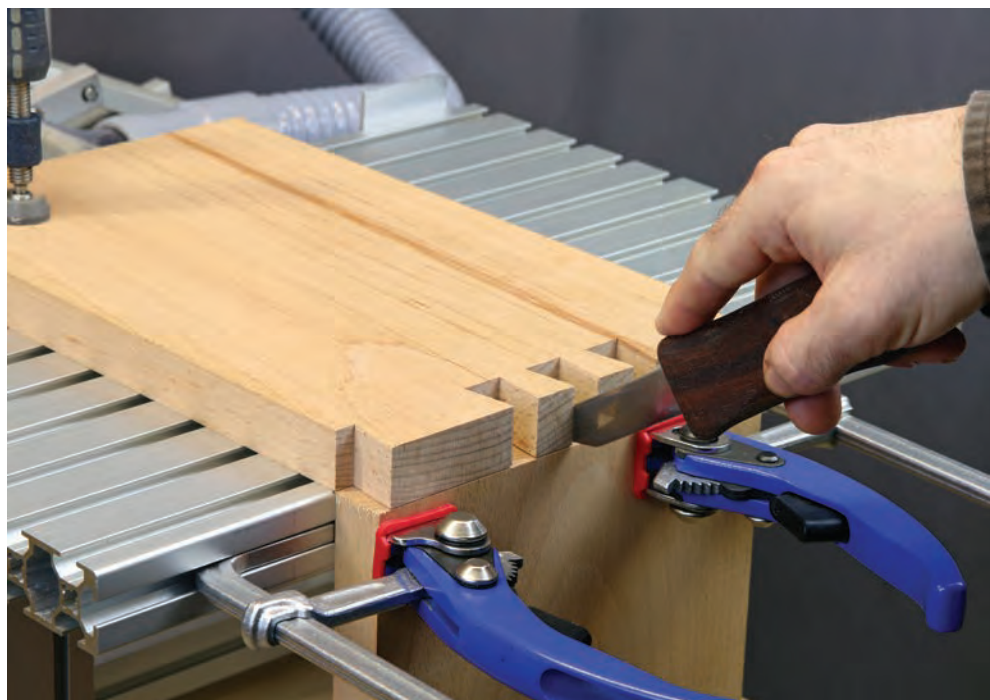

**Mount the pins test piece on the table then dial in the template height.** Holding the bearing against one side of a template, move the template holder up and down until the router bit is perfectly aligned with part of your pins layout. Then lock the template holder at that height.



**Cut test pins.** It is still important to use a test board for your first pins attempt, but the fit will be extremely close, if not dead-on. If you need to adjust the templates up or down, record the height of the template holder with a simple pencil mark so you can repeat the process next time you make dovetails.

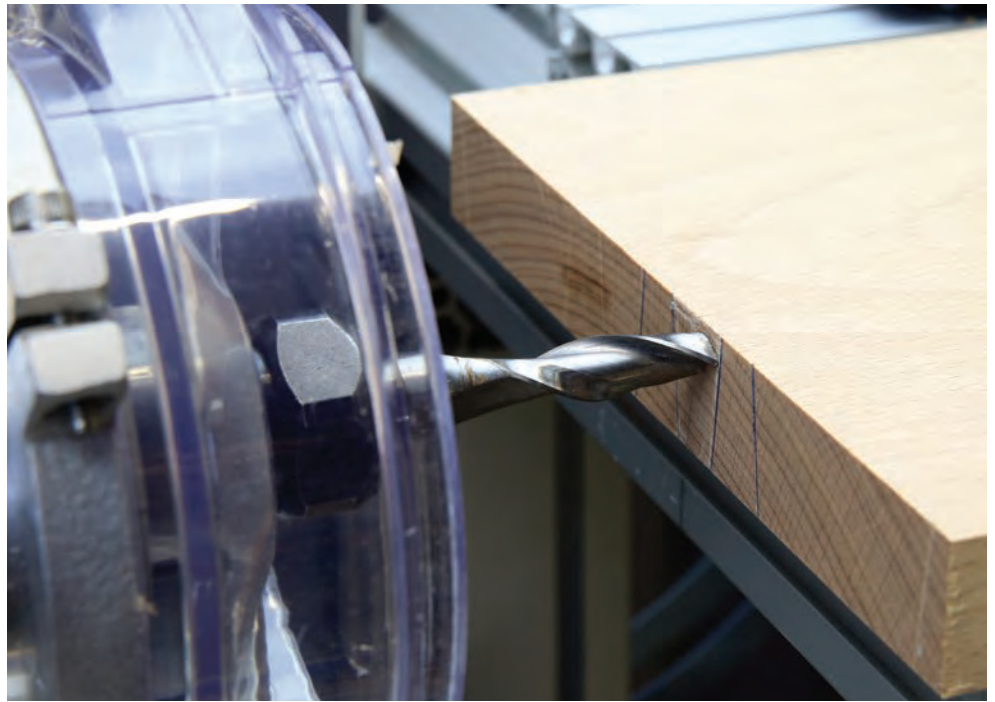

**Don't forget to set the depth.** Set the depth stop so the straight bit ends up right at your scribed baseline, or just past it for pins that are slightly proud.

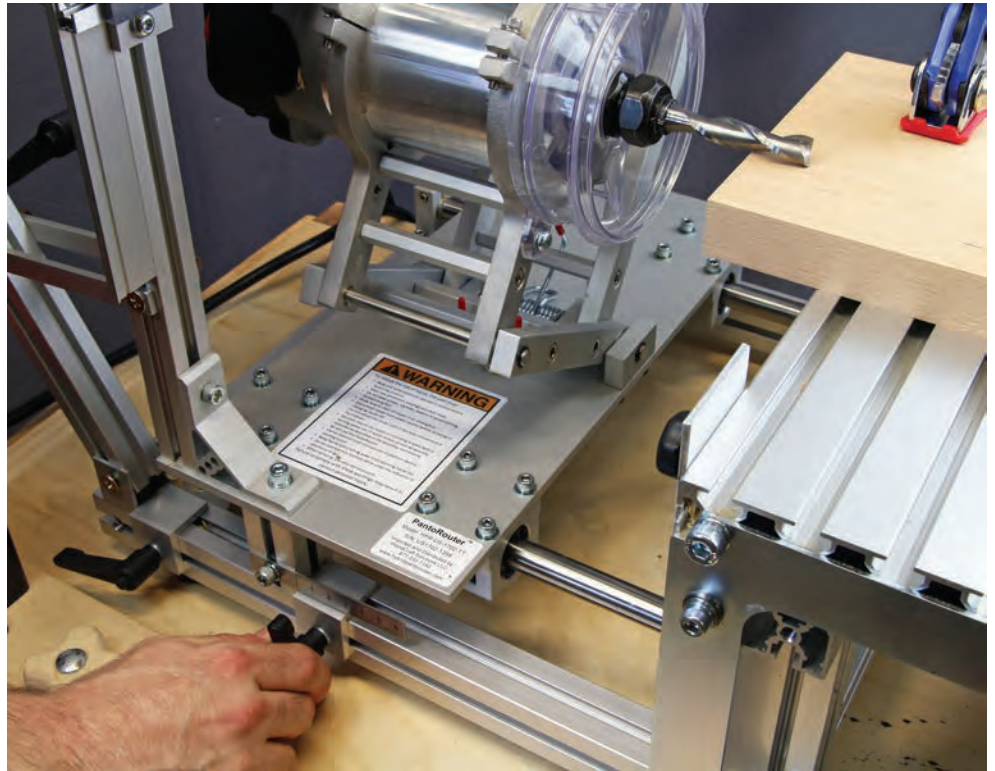

## Cut pins with confidence

**Nothing changes.** For perfect-fitting pins, the templates stay right where they are, and you simply ride the outside edges. The fence also stays put. Once again, slow down when breaking through the bottoms of your cuts, and tearout will be virtually eliminated.

## Proof is in the pudding

**Stacks of perfect dovetails.** The 2-in-1 templates ensure a perfect fit, no matter how you space the pins and tails



## Great trick for asymmetrical dovetails

For some boxes and drawers, you'll want an asymmetrical array, which will need to be reversed for opposite corners of the box. Here's how to reverse any template array.

**Record it.** Get the templates where you want them for one of the joints, and use a long folded piece of paper as a story stick for marking the centers of the templates, as well as the center of the template holder. Then cut pins and tails as usual.



**Reverse the array.** To create the same array in reverse, just unfold the paper and extend your marks a little. Now you can fold and flip your paper ruler, and use the marks to re-center the array on the template holder and reset all of the templates.



**Happy  
PantoRouting!**



# Limited Edition Templates and Accessories

## Diamond

Finished diamond shaped mortise and tenon is about 3/4" X 2-1/2"



## Bowtie

Finished bowtie mortise and tenon is about 3/4" X 2-1/2"



## Monster Mortise and Tenon Set

Make 3/4" and 1" mortise and tenon with our standard MT-3 and MT-5 templates. These are best suited to construction lumber or larger projects. The set includes the two large bits for the mortises and the two large guide bearings for the tenons. Tenons are cut with the 1/2" upcut spiral bit so they can be up to 2" long.



## Dowel Templates

Dowels can be cut from the same wood as your workpiece and used as floating dowels (traditional method) or as integral dowels or round tenons. The dowel templates use the 10mm (purple) guide bearing on the inside to make the dowel mortise, hole or pocket and the same sizes as our mortise and tenon templates for the dowels (tenons).

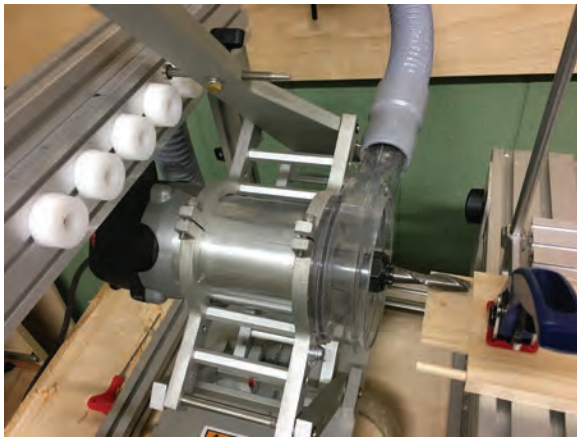
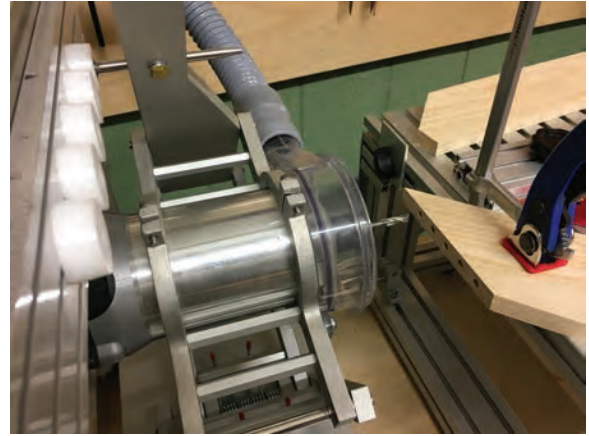

Notes:





Copyright 2019 - WoodCraft Solutions LLC

Distributed in North and South America,  
New Zealand and Australia by:  
WoodCraft Solutions LLC

[www.PantoRouter.com](http://www.PantoRouter.com)  
[info@PantoRouter.com](mailto:info@PantoRouter.com)  
+1-877-333-7150

# Matching mortises and tenons in minutes

Copyright 2017 WoodCraft Solutions LLC

With its 2-to-1 movement and 2-in-1 templates, the PantoRouter™ makes faster, better-fitting mortises and tenons than any other method. The templates are the key, capturing the guide bearing in their center slot to make the mortise, and then guiding the guide bearing around the outside for foolproof tenons too. A slanted guide surface allows incredibly fine adjustments to tenon fit, for perfect results right off the machine.

The standard package includes an array of templates for various joint sizes and orientations, the ALL-IN Package has even more, and all are available à la carte.

The genius of the system doesn't stop at the templates. Setting up the template holder, fences and depth stop is just as fast and easy. And once they are set, you can make stacks of joints in minutes, dead-accurate and dust-free thanks to our new dust-collection attachment.

Follow the process shown here, and you'll make better joints than ever before, in a fraction of the time.

## Setup steps

Choose your template. By changing the bit and guide bearing, you can make joints of any thickness, so all that matters here is length (the 2-to-1 pantograph ratio means joints are always half the length of a given template). All templates have tabs on the back that keep them parallel on the template holder in the template holder, and small nuts that slide into T-slots.



Center the template side to side. Put the round guide bearing in the PantoRouter's arm and the pointed centering jig in the router chuck. Then just insert the round guide bearing into the hole in the center of the template and move the template side to side until the sharp guide bearing is aligned with the table's centerline. Lock the template in that position and it's centered too.

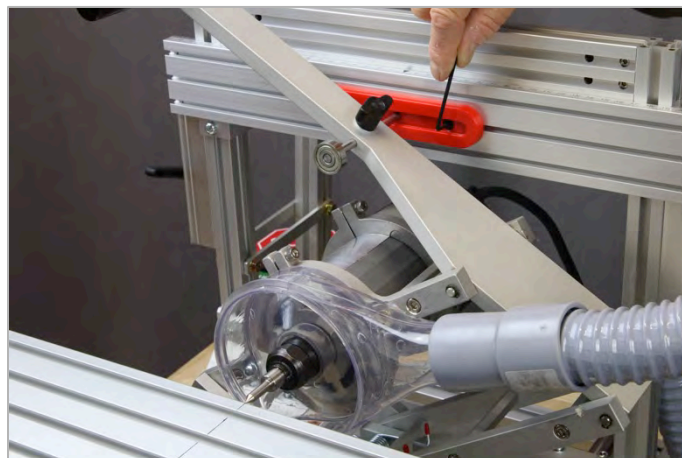

Center the template vertically. This step is even easier. Once you've properly set the thickness gage below the template holder (see the assembly and setup instructions for the PantoRouter), all you need to do is place a cutoff from one of your workpieces, or a workpiece itself, between the template holder and thickness gage to know you have centered the template and router on the stock. Lock the template holder in that position.



Measure the tenon piece to set the fence. Even though you'll be mortising first, use the tenon piece here if your M&T joint will be on the end of your workpiece. Measure its width then adjust the fence to that same dimension. The ruler on the fence is half-scale, making the fence self-centering. *To avoid pulling the fence out of square, always tighten the front knob first, as shown, before tightening the knob on the fence.*



### **Mortises first**

Insert the mortise guide bearing. Choose the 10mm guide bearing that fits the inside of the template, and insert it into the template slot. Also, insert the bit for the mortise you are cutting. See the reference chart on page 8 of this guide.



Clamps and clamp helpers. The standard clamps work in most situations, but for mortising, make simple clamp helpers like the one shown to get pressure where you need it. Be sure not to clamp directly over the area to be mortised, as the clamp could end up cracking the mortise wall.

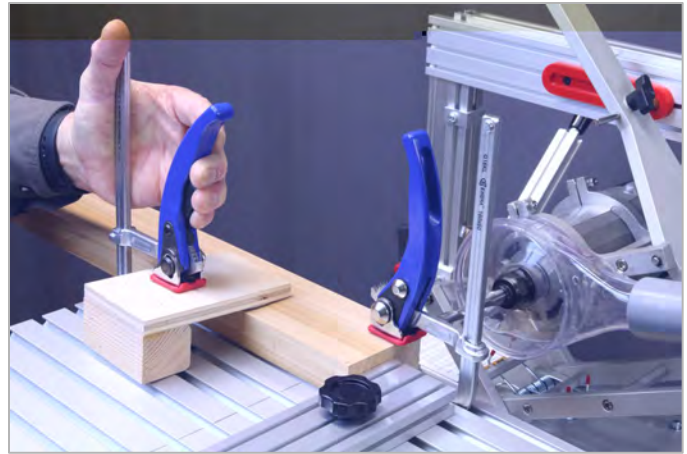

Set the depth. The excellent Whiteside bits included with your PantoRouter can cut just over 2 in. deep, so that is your depth limit for mortises. Just touch the bit to the work and slide the depth stop just past the 2 in. mark. We'll be using a 2 in. tenon in these examples, and we want a little extra room for excess glue at the bottom of the mortise.

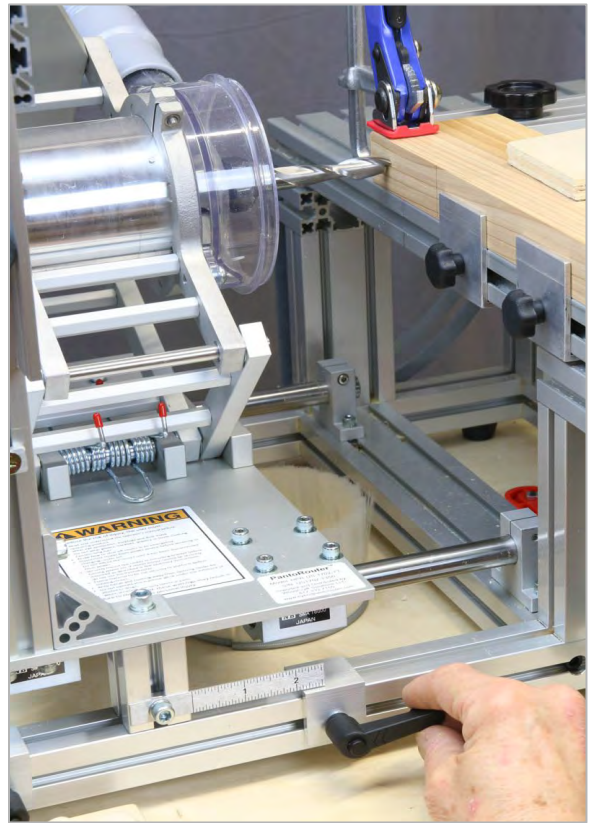

Dust shroud goes back on. The effective and convenient dust port has a brush-style shroud that comes off easily for setup and goes back on just as quickly.

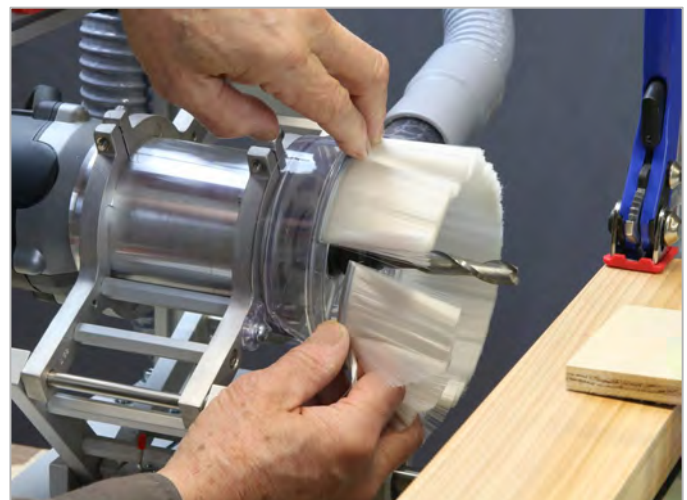

Mortising is fast and foolproof. Take shallow passes, moving the router back and forth with one hand and forward with the other, until the depth stop bottoms out. That's it! Note the two Fence/Stops on the table that align the workpiece, and also how effective the dust collection is.

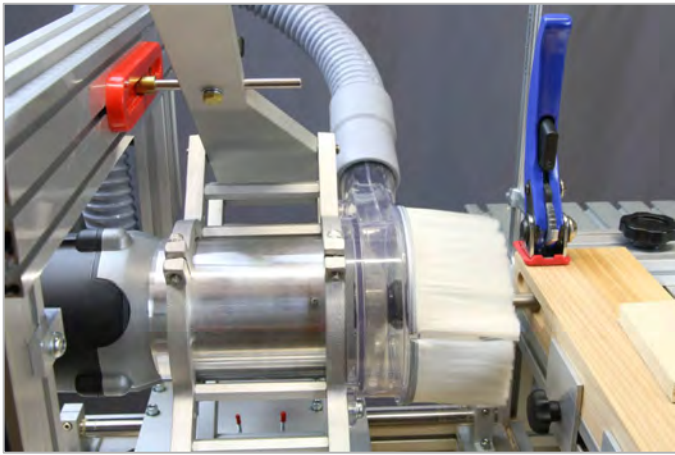

### Tenons second

New guide bearing, same bit. In most cases, you'll need a different guide bearing to make the matching tenon, but you might be able to use the same mortising bit. Check the chart on page 8 to be sure. Also, push the guide bearing to the back edge of the template for your first tenon attempt.



Reset the depth stop. Touch the end of the workpiece with the bit then set the depth as before. Here we want the tenon to be 2 in. long.

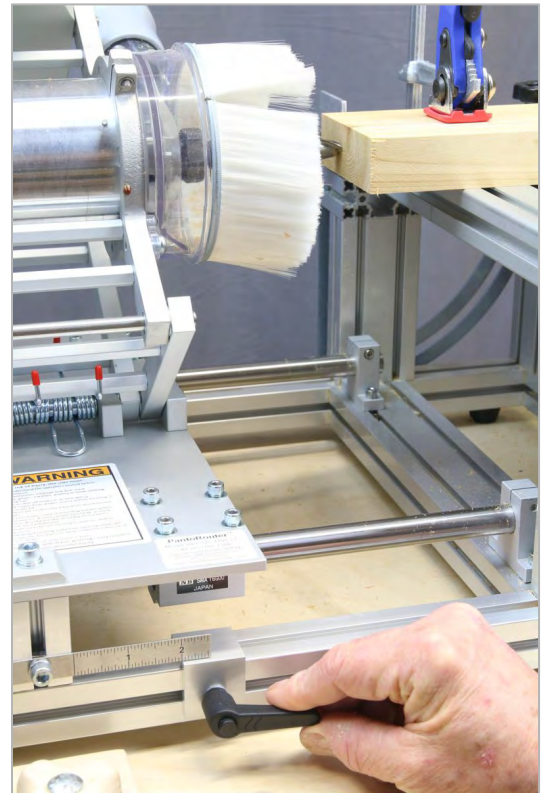

Safety check. Check that you've extended the workpiece far enough so the bit will clear the table at its full cutting depth.

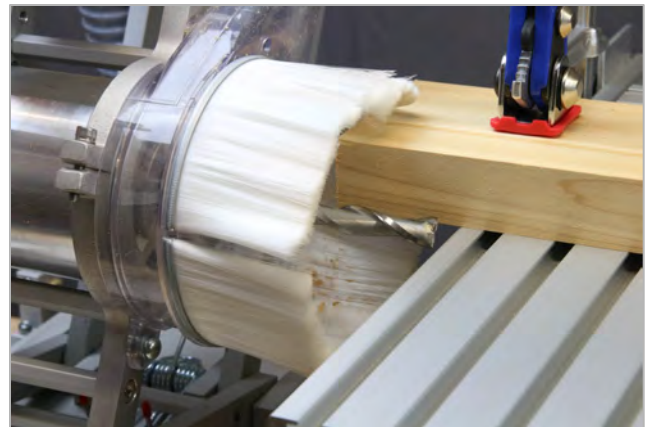

Tenoning is just as fast and foolproof. Use climb cuts for a clean shoulder, working your way deeper and farther down the tenon as you go, until the bearing is riding the template and the depth stop is bottomed out.

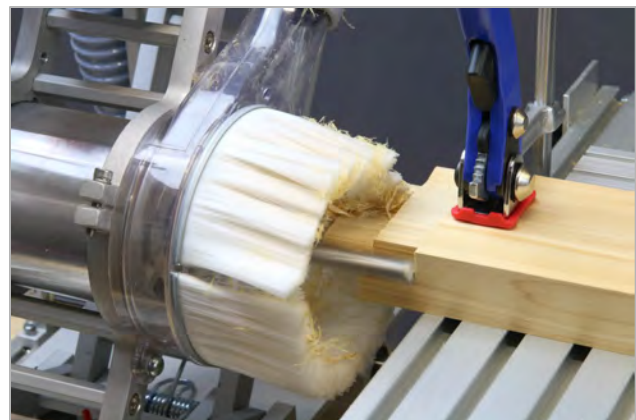

The mechanical advantage ratio is actually 2.5:1 at the handle, so you'll have perfect control, even though you are climb-cutting all the way.

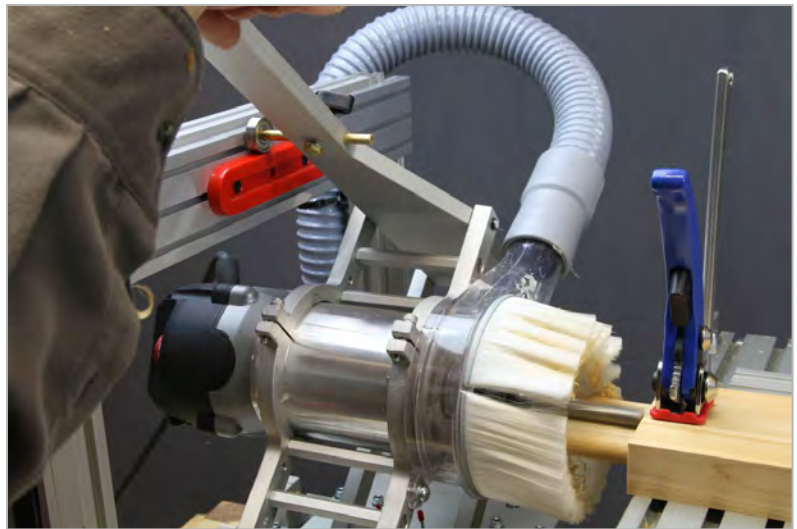

Check the fit. The tenon could be just a bit fat at this point.



Adjustments are amazingly easy. The templates have a slightly tapered outer edge, so moving the guide bearing outward slightly adjusts the fit by a few thousandths of an inch. Once you dial in the fit, you can crank out piles of cleanly cut, dead-accurate tenons in minutes.

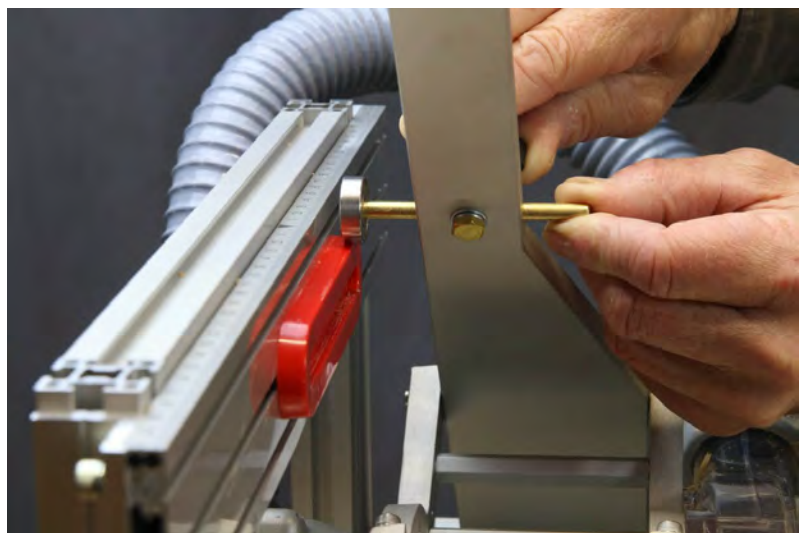

## Multiple tenons are just as easy

For wide workpieces, combine templates. Use a square and the scale on top of the template holder to align the templates. Make sure to leave room between them for the router bit to pass through (remember the 2-to-1 scale again as you select your guide bearing and space the templates).

Make a test run. To be sure the mortises and tenons will fall in the right place, cut mortises in some scrap.

Two mortises are almost as fast as one. You just need to stop to pull the guide bearing out of the center slot of one template and put it into the other.

Two tenons in one minute. Like before, use climb cuts to make a series of shallow passes, working your way toward full depth, and adjust the guide bearing outward to dial in the fit.

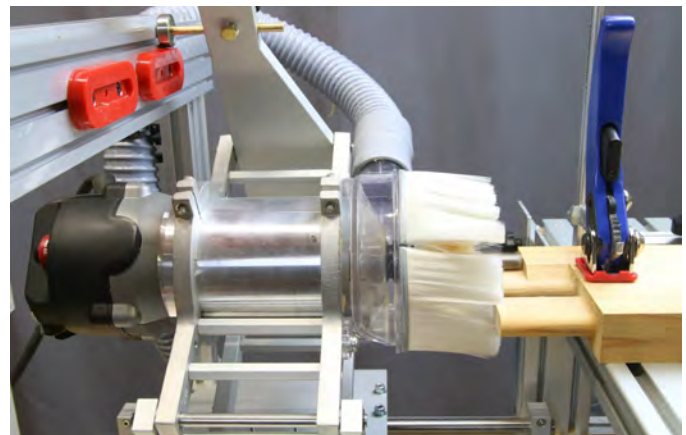
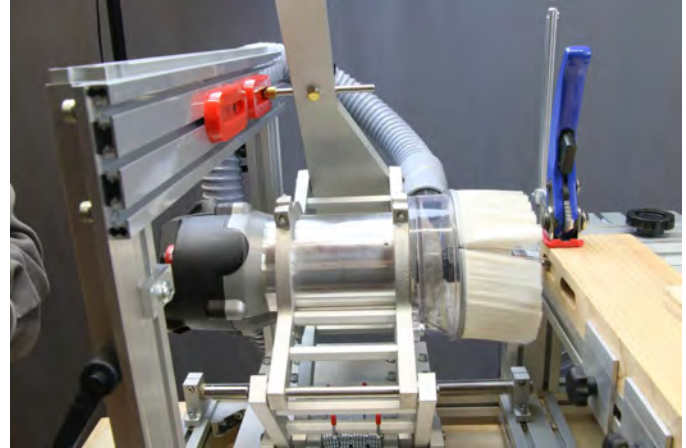



Perfection. You will get perfect alignment and a perfect press-fit right off the machine. Note that the mortises are just a tad wider than the tenons. This is built into the templates, too. It doesn't affect strength but allows the convenience of side-to-side adjustment for bringing parts flush to each other.

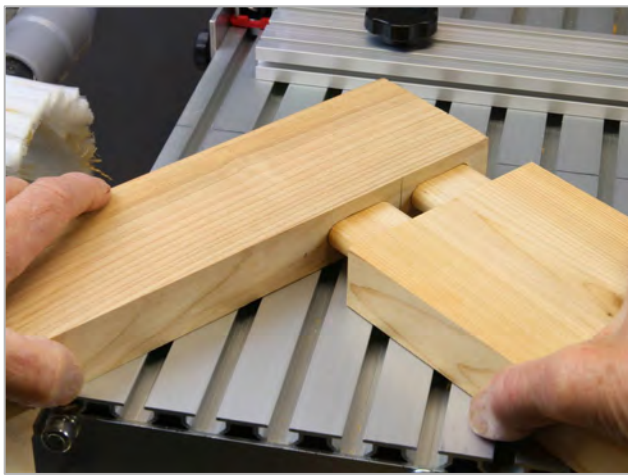

### Mortise and Tenon Joinery Examples

Size	Mortise		Tenon		Notes:
	Guide Bearing	Bit for Mortise	Guide Bearing	Bit for Tenon	
1/4" M&T	10mm	1/4"	10mm	1/2"	The mortise and tenon are mirror images so position the workpieces with indexing against the fence accordingly. Cut the mortise first then adjust the fit of the tenon. Move the guide bearing down the tapered template (away from the template holder) to make the tenon smaller.
3/8" M&T	10mm	3/8"	15mm	1/2"	
1/2" M&T	10mm	1/2"	22mm	1/2"	

Other combinations are also possible. The above are common sizes using the 1/2" bit for all tenons. The mortise is cut with the bit size of the desired tenon thickness.

### Advanced Joinery

Quadro Mortise and Tenon using four MT-3H templates

3/8" bit and 10mm guide bearing for both mortise and tenon

Set the spacing between templates just over 10mm so guide bearing will pass through

